Smart Battery Power Management

FEATURES

- Single-chip battery charger controller and gas gauge.
- Provides cell balance control output for charge control.
- Drives 5-segment LED display for remaining capacity indication.
- User-selectable charge-control data sets.
- Output for charging indicator
- Maximum voltage charge control for Individual cells.
- Provides secondary cell protection functions.

APPLICATIONS

- Portable DVD Player and Computers.
- 2-Cell Battery Packs or Backup Devices.

PACKAGE OUTLINE

- 24 Pin SOP or SSOP package.

GENERAL DESCRIPTION

The SS4003 Charger and Gas Gauge combo IC for battery pack or in-system installation provides an accurate charge control and maintains an accurate record of available charge in rechargeable batteries. The SS4003 is dedicated for Li-Ion chemistries, and monitors capacity and other critical parameters. The SS4003 uses an A-to-D converter for voltage and current measurement. The cumulative charge into (or discharge from) the battery is continuously calculated. The on-chip ADC also monitors individual cell voltage in the battery pack and allows the SS4003 to generate charge control signals to charge the pack safely. The SS4003 provides outputs to drive LEDs to depict remaining battery capacity from full to empty with a 5-segment display. The SS4003 uses the pre-defined self-discharge rate and other compensation factors stored in the ROM to accurately adjust remaining capacity for use and standby conditions based on time. The SS4003 also automatically calibrates or learns the true battery capacity in the course of a discharge cycle from near full to near empty level.

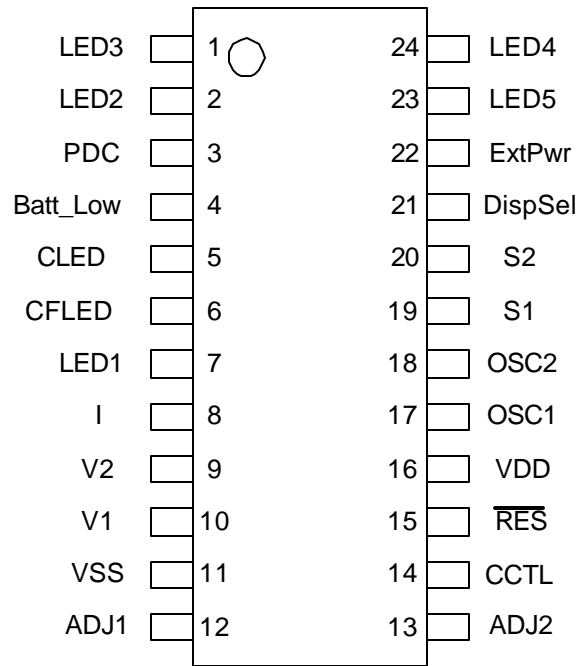
PIN CONFIGURATION

SS4003

PIN DEFINITION

Pin Name	Pin No	I/O	Description
LED3	1	Output	Remain capacity display LED3
LED2	2	Output	Remain capacity display LED2
PDC	3	Output	Power down control output (high enable)
Batt_Low	4	Output	Secondary battery pack protection control output
CLED	5	Output	Charge state indicator
CFLED	6	Output	Charge full state indicator
LED1	7	Output	Remain capacity display LED1 (LSB)
I	8	Input (A)* ¹	Current sense input: 2.5V @ 0mA, ±0.5V/A
V2	9	Input (A)*	High potential cell voltage input
V1	10	Input (A)*	Low potential cell voltage input
VSS	11	Input	Power ground
ADJ1	12	Output	Low potential cell balanced control output
ADJ2	13	Output	High potential cell balanced control output
CCTL	14	Output	Charge control output (PWM)
RES	15	Input	Reset input point
VDD	16	Input	Power supply
OSC1	17	Input	Oscillator input 1
OSC2	18	Output	Oscillator output
S1	19	Input	ROM data set select input 1
S2	20	Input	ROM data set select input 2
DispSel	21	Input	Battery remain capacity display control (falling edge trig)
ExtPwr	22	Input	External power plug in input (low true)
LED5	23	Output	Remain capacity display LED5 (MSB)
LED4	24	Output	Remain capacity display LED4

* Input (A): Analog A/D input

* Note 1: -0.5V/A, for charge mode and +0.5V/A for discharge mode

Charging Indicator

The SS4003 provides an output pin to indicate the battery charge status. The CLED output shows the battery pack is in charge mode. When the external electric power is plugged in, the CLED is on (low) and SS4003 starts to charge. The CLED turns off (high) when charge full condition is reached or external power is removed. In case of charge fault condition, the CLED will alter the output state (high/low) in every second. The CFLED will turn on (low) when the battery is in charge full state during charging period. CFLED will turn off (high) in all other conditions.

Battery Remaining-Capacity Indication

The battery remaining-capacity is indicated by 5 LED output pins, LED1, LED2, LED3, LED4 and LED5. Low voltages on output pins drive LEDs ON. To reflect the remaining capacity the LED outputs are ON inclusively from LED1 to LED5. The more LED outputs ON the higher the capacity. When all 5 LEDs are ON, the battery capacity reaches above 90% of the Full Charged Capacity. One, two, three and four LEDs are ON when the capacity is above 10%, 25%, 50% and 75% of the Full Charged Capacity, respectively. If the relative state of charge was lower than 10%, the LED1 flashes every second. In the charge or discharge state, the LEDs keep showing the battery capacity. For saving the battery energy, the LEDs are turned off after about 5 seconds if not in the charge or discharge state. If a negative going signal is applied to DispSel pin and the pack is neither in charge mode nor in discharge mode, the relative state of charge display function will activate. The display function will terminate after 5 seconds if no state change occurred during the period of time.

Reset

The SS4003 is at reset state either first connected to the battery pack or the supply voltage goes below $V_{LV.R}$. On hard reset, the SS4003 initializes and reads the configuration data to configure the battery pack. A suggested Reset circuit is illustrated in Application Circuits 1.

Sleep mode

The SS4003 switches into the sleep mode either no charge flow detected for more than 30 seconds or the relative state of charge is 0%. In the sleep mode, most of logic circuitry in the chip is turned off to minimize the power consumption. SS4003 resumes operation either an external power is plugged in or detects current flow through the sense resistor or display function is activated.

Measurement Operation

The SS4003 accumulates charge and discharge current and estimates self-discharge. Charge current is controlled according to state-of-charge of the battery. The battery capacity is denoted as Remaining Capacity (RCAP) in terms of relative state of charge, represents the available battery capacity at any given time. Charging increases the RCAP. Discharging and self-discharge will decrease the RCAP. An internal register is used to monitor the amount of discharge so as to adjust the Full Charge Capacity (FCCAP). FCCAP is updated only if a complete cycle of battery discharge from full to empty level is done and not interleaved by any charge operation. Therefore, the SS4003 adapts its capacity determination based on the actual conditions of discharge. The battery's initial full capacity is set to the value stored in a ROM. Until FCCAP is updated, RCAP counts up to, but not beyond, this threshold during subsequent charge. The battery's empty state is also programmed in the ROM. The battery low percentage stores the percentage of FCCAP while the battery voltage drops to the PEV threshold.

1. Full Charge Capacity (FCCAP):

FCCAP is the latest measured discharge capacity of the battery. On initialization, FCCAP is set to the value stored in the ROM. During subsequent discharge, FCCAP is updated with the latest recognized complete discharging (or learning cycle), representing a discharge from full to near empty. A learning cycle is necessary for updating the FCCAP register. The FCCAP also serves as the 100% reference threshold used by the relative state-of-charge calculation and display.

2. Design Capacity (DCAP):

The DCAP is the user-specified battery capacity and is programmed in the ROM.

3. Remaining Capacity (RCAP):

RCAP counts up to the value of FCCAP during charge and counts down during discharge and self-discharge. RCAP is set to a predefined value if the pack voltage drops down to a predefined level. If RCAP is equal to the predefined value, RCAP keeps until voltage drops below the predefined level. To prevent overstatement of charge during periods of overcharge, RCAP stops incrementing when $RCAP = FCCAP$.

4. Cumulated Discharge Count (CDC):

The Cumulated Discharge Count is used to record the usage of the battery which response to the life of battery. The CDC counts up during discharge independent of RCAP and can continue increasing after RCAP has decremented to 0. The CDC resets to 0 when $CDC = FCCAP$.

Charge Counting

Charge activity is detected based on a positive voltage on pin I. The voltage input at pin I is measured and converted into current through the sense resistor. If charge activity is detected, the SS4003 increases the RCAP. Charge actions increment the RCAP according to the cumulated charge counts.

Discharge Counting

Discharge activity is detected based on a negative voltage on pin I. The voltage input at pin I is measured and converted into current through the sense resistor. If discharge activity is detected, the SS4003 decreases the RCAP.

Self-Discharge Estimation

Because of the self-discharge, the SS4003 decrements RCAP periodically until the charge full or charge empty condition is detected. The estimated self-discharge rate is programmed in a ROM.

Charge Control

SS4003 utilizes PWM methodology for charge control. There are three types of charge control, trickle charge, constant current charge, and constant voltage charge. The SS4003 updates the charging current based on the battery's voltage. The SS4003 uses current taper detection for Li-Ion primary charge termination and over voltage detection to suspend charging. The SS4003 also provides a number of safety terminations based on battery capacity, voltage, and conditions of individual cell. The PWM output control range is from 0% to 99%. Two types of control can be applied in typical applications. Application Circuit 2 shows a PWM to DC voltage conversion circuits that can be used in linear control applications.

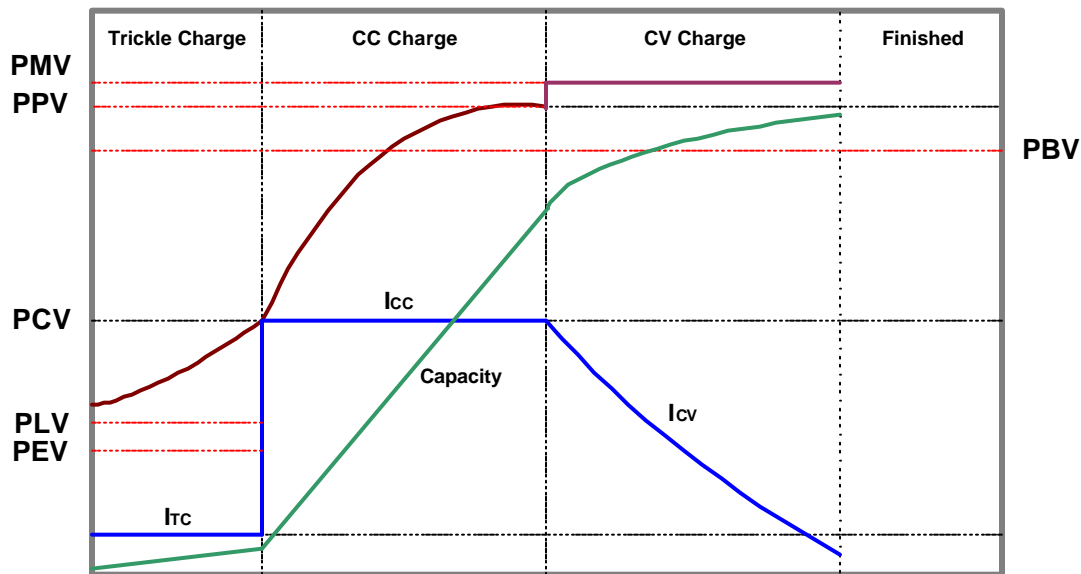

Voltage Thresholds

In conjunction with monitoring the voltage at pin I for charge/discharge currents, the SS4003 monitors the battery potential through the pin V. The voltage potential is determined through a resistor-divider network on tips of cells. The battery voltage is obtained by measuring the input voltages on tips of cells and dividing factors stored in a ROM. The cell voltages are monitored for the battery low (PLV) protection, battery exhausted (PEV) and charge control. As the pack voltage is lower than the PLV, the SS4003 will enable the battery low control output through the Batt_Low pin for secondary battery pack protection. Exhausting charge threshold levels are used to determine when the battery has reached a pre-programmed “empty” state. If a validate discharge period is present, the full charge capacity will update at this point. Four pre-programmed voltage thresholds, PCV, PBV, PPV and PMV, are used to determine the charge state. When the pack voltage is lower than the PCV, the charge control is in the trickle charge mode. In the trickle charge mode, the charge current is controlled at a level below 0.2C. The charge control will enter the pre-defined constant current charge mode if the pack voltage is higher than the PCV. The cell balance function activates after the pack voltage reach the PBV and keep in active state until both cells voltage are over PBV. As the pack voltage goes higher than the PPV, the charge mode transits from constant current to constant voltage charge mode. Through the whole charge period, the SS4003 continues monitor the individual cell voltage and keep both cell voltages not larger than the PMV (predefined cell maximum voltage).

Cell Balancing

The SS4003 also provides the cell balance function. Passive type of cell balance technologies is implemented in SS4003. The cell balance control output pin controlled the current bypass path during the charge period. The cell balance function is activate when one of the cell voltage over the pack balance start voltage (PBV). The cell balance function will turn off when both of the cell voltages are over the PBV.

Battery Management Data Selections

The SS4003 reserves 4 sets of battery information that can be selected by pin S1 and pin S2. If S1 and S2 inputs both are grounded, the first set will be used. The set information include: Full-charge capacity (FCCAP), Voltage at 50% of FCCAP, Pack maximum voltage, End-discharge voltage (3% of FCCAP), charge taper current, charge current, and trickle- charge current etc. Battery data could be sent to SSC in advance, and SSC could program the customer specified data sets.

ABSOLUTE MAXIMUM RATINGS

Power Supply Voltage.....V_{SS}-0.3V to V_{SS}+6.0V
 Input Voltage.....V_{SS}-0.3V to V_{DD}+0.3V

Storage Temperature.....-50? to 125?
 Operating Temperature.....-40? to 85?

D.C. Characteristic

 T_a=25?

Symbol	Parameter	Test Conditions		Min.	Typ.	Max.	Unit
		V _{DD}	Conditions				
V _{DD}	Operating Voltage	-	f _{SYS} =4MHz	4.75	5	5.25	V
I _{DD1}	Operating Current (Crystal OSC)	5V	No load, f _{SYS} =4MHz ADC disable	-	2	4	mA
I _{DD2}	Operating Current (RC OSC)]	5V	No load, f _{SYS} =4MHz ADC disable	-	2.5	4	mA
I _{STB1}	Standby Current (WDT Enabled)	5V	-	-	-	10	μA
V _{IL1}	Input Low Voltage for I/O Ports,	-	-	0	-	0.3V _{DD}	V
V _{IH1}	Input High Voltage for I/O Ports,	-	-	0.7V _{DD}	-	V _{DD}	V
V _{IL2}	Input Low Voltage (RES)	-	-	0	-	0.4V _{DD}	V
V _{IH2}	Input High Voltage (RES)	-	-	0.9V _{DD}	-	V _{DD}	V
V _{LVR}	Low Voltage Reset	-	-	2.7	3	3.3	V
I _{OL}	I/O Port Sink Current	5V	V _{OL} =0.1V _{DD}	10	20	-	mA
I _{OH}	I/O Port Source Current	5V	V _{OL} =0.9V _{DD}	-5	-10	-	mA
V _{AD}	A/D Input Voltage	-	-	0	?	V _{DD}	V
E _{AD}	A/D Conversion Error	-	-	-	±0.5	±1	LSB
I _{ADC}	Additional Power Consumption if A/D Converter is Used	5V	-	-	1.5	3	mA

A.C. Characteristics

 T_a=25?

Symbol	Parameter	Test Conditions		Min.	Typ.	Max.	Unit
		V _{DD}	Conditions				
f _{SYS}	System Clock	-	5V	-	4000	-	kHz
t _{WDTOSC}	Oscillator Period	5V	-	32	65	130	μs
t _{RES}	External Reset Low Pulse Width	-	-	1	-	-	μs
t _{SST}	System Start-up Timer Period	-	Wake-up from HALT	-	1024	?	*t _{SYS}
t _{INT}	Interrupt Pulse Width	-	-	1	-	-	μs

Operating frequency:

4 MHz (OSC1 PIN take 82K resistance to Vss, 470pF capacitance to Vdd, as Application circuit1)

Application Circuit 1 :

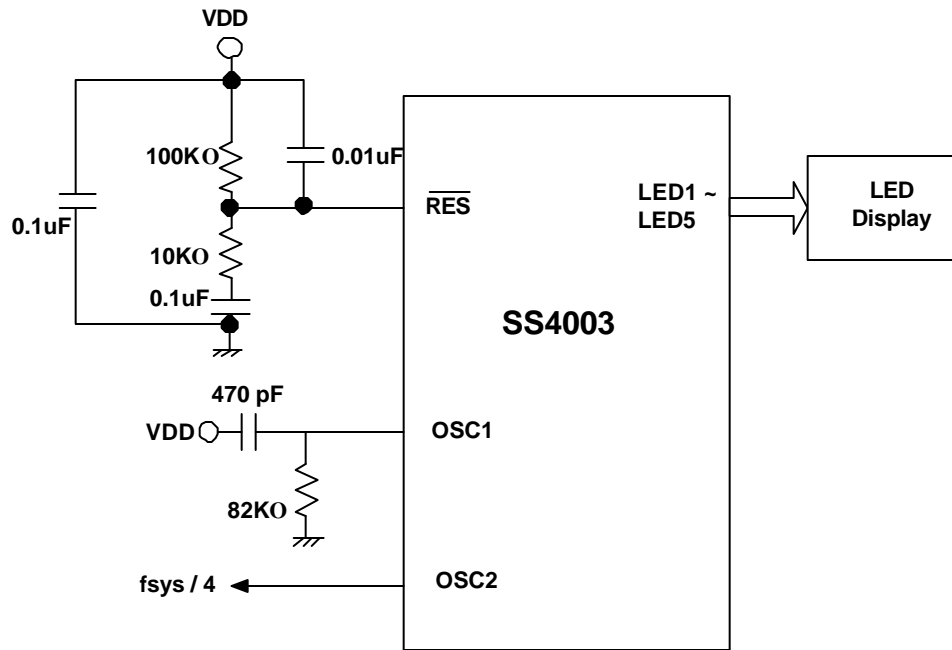

Application circuit 2 :

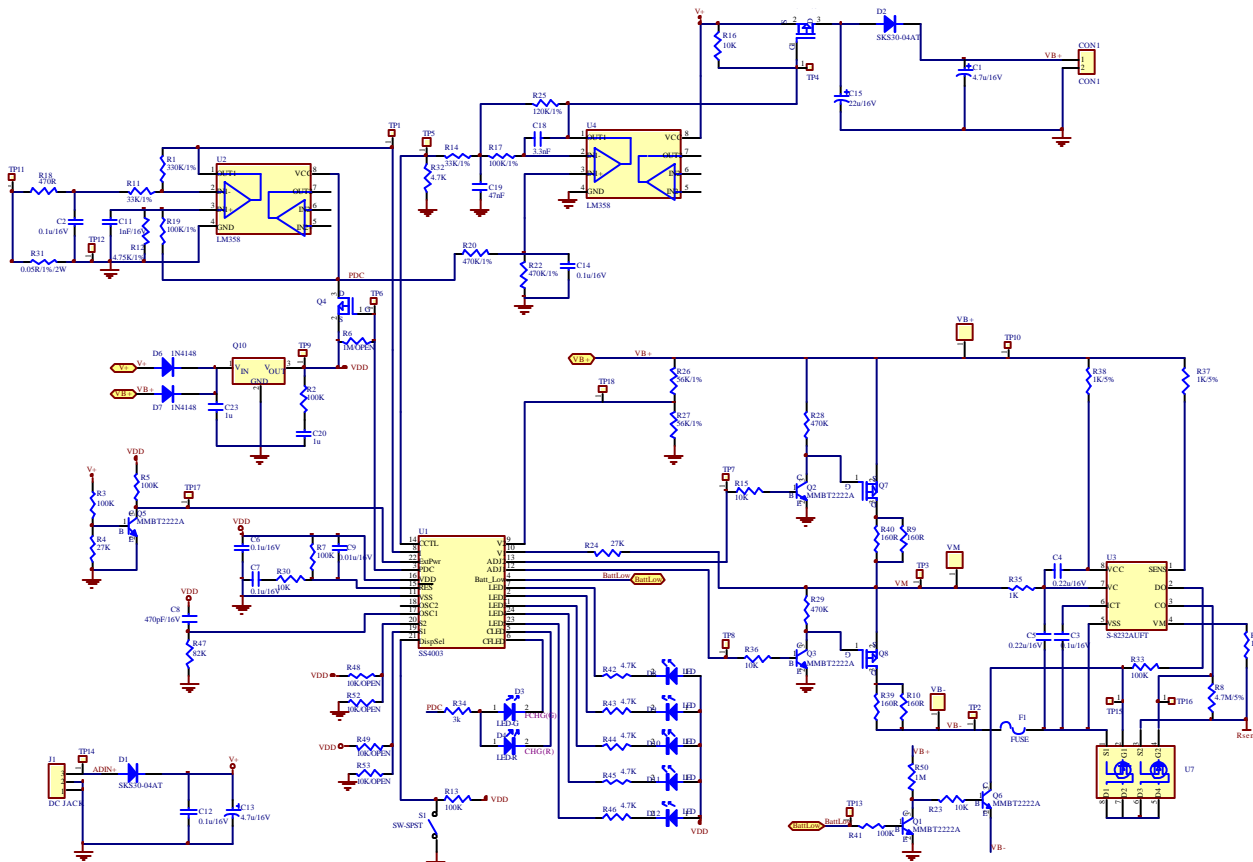

PACKAGE DIMENSIONS:

SO-24

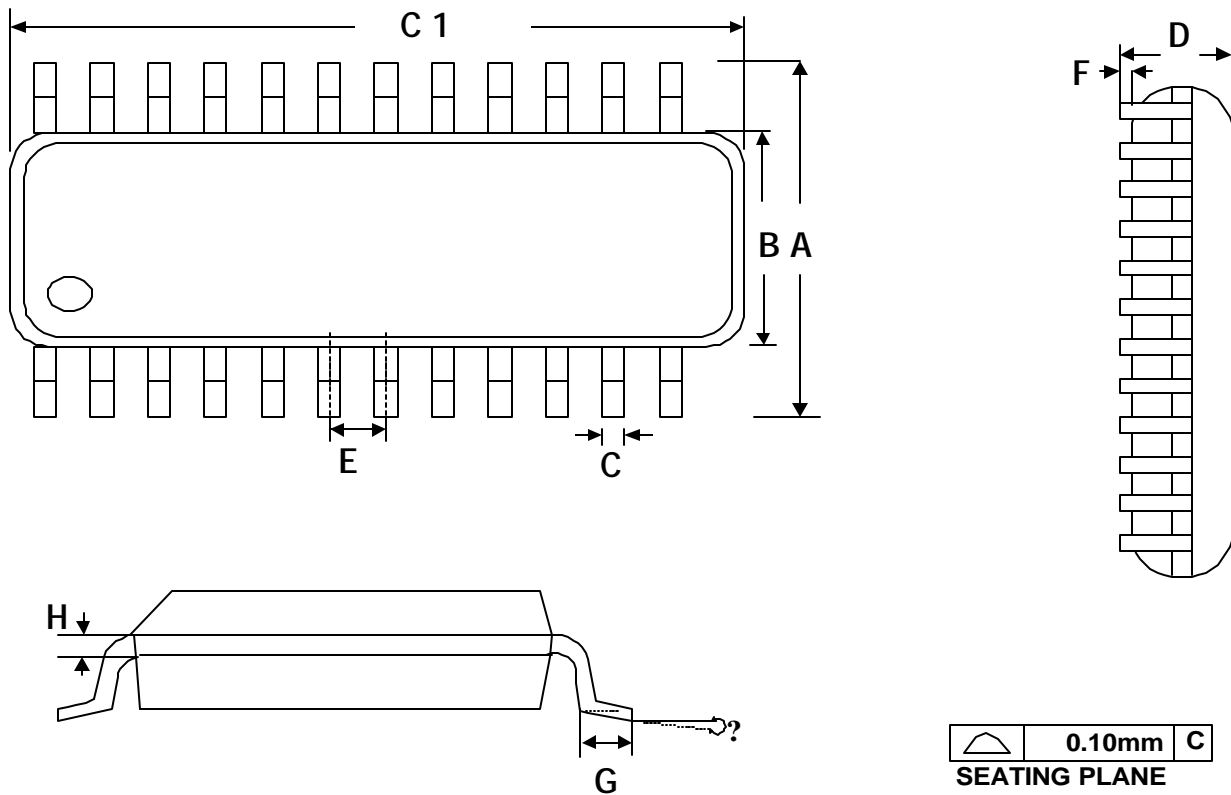

Symbol	Dimension in mil		
	min.	nom.	max.
A	394	-	419
B	290	-	300
C	14	-	20
C1	590	-	614
D	92	-	104
E	-	50	-
F	4	-	-
G	32	-	38
H	4	-	12
?	0°	-	10°

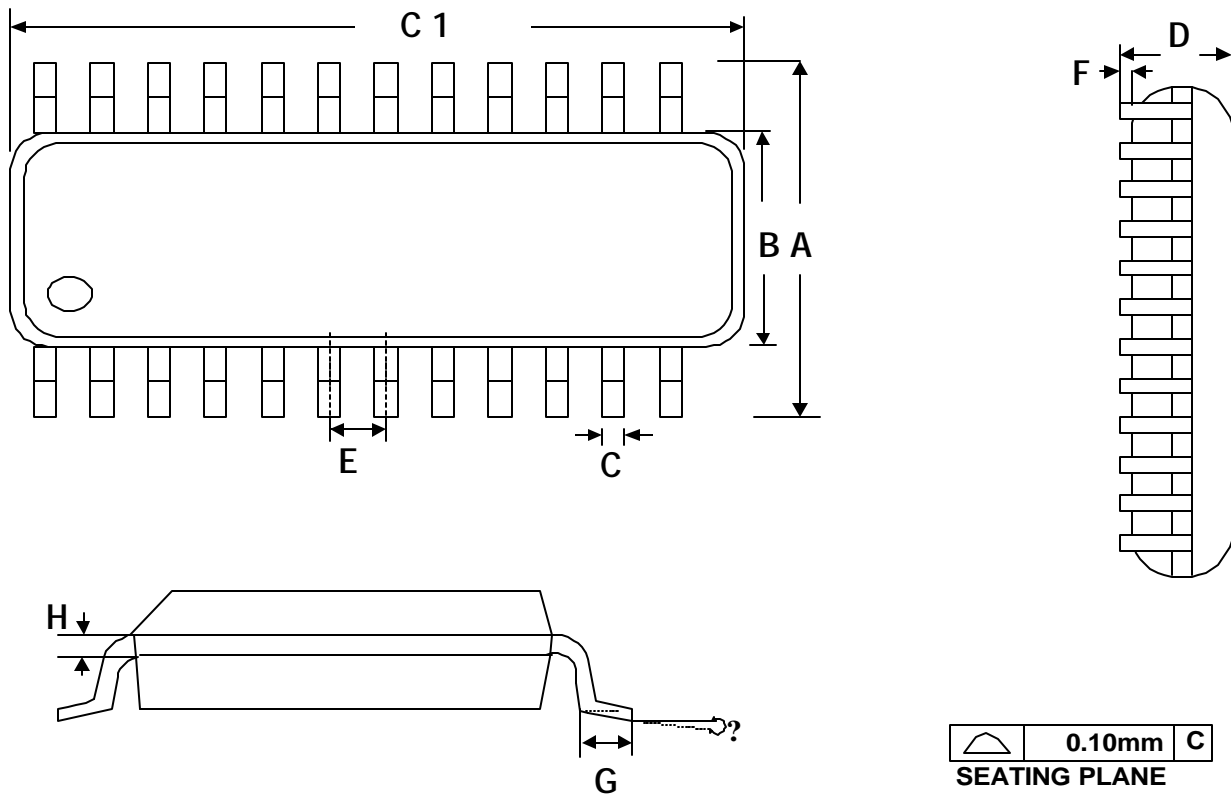
SSOP-24

Symbol	Dimension in mil		
	min.	nom.	max.
A	228	-	244
B	150	-	157
C	8	-	12
C1	335	-	346
D	54	-	60
E	-	25	-
F	4	-	10
G	22	-	28
H	7	-	10
?	0°	-	8°

Information furnished by Silicon Standard Corporation is believed to be accurate and reliable. However, Silicon Standard Corporation makes no guarantee or warranty, express or implied, as to the reliability, accuracy, timeliness or completeness of such information and assumes no responsibility for its use, or for infringement of any patent or other intellectual property rights of third parties that may result from its use. Silicon Standard reserves the right to make changes as it deems necessary to any products described herein for any reason, including without limitation enhancement in reliability, functionality or design. No license is granted, whether expressly or by implication, in relation to the use of any products described herein or to the use of any information provided herein, under any patent or other intellectual property rights of Silicon Standard Corporation or any third parties.