

Stereo Headphone Power Amplifier

FEATURES

- High performance Class AB amplifier
- High signal-to-noise ratio
- Low distortion
- Low power consumption
- Large output voltage swing
- Excellent power supply ripple rejection
- Supply voltage range of 3.0V to 6.5V
- Surface-mount package - SO-8

APPLICATIONS

- CD-ROM
- DVD-ROM
- CD-R/W
- MP3
- Portable Stereo

DESCRIPTION

The SS8021 is an output-rail-to-rail stereo audio power amplifier housed in an 8-pin SOP package capable of delivering 125mW of continuous power into 16Ω loads and 75mW into 32Ω loads with THD <0.1% per channel.

The gain of the amplifiers can be easily set with two external resistors - R_I (input resistor) and R_F (feedback resistor).

The SS8021 is a dual channel, low voltage, low power, high performance amplifier. The quiescent current is typically 3mA at 5V. With excellent AC performance (small THD), it can be designed into a wide range of headphone driving applications.

ORDERING INFORMATION

SS8021(G)XX

Packing: TR Tape and reel
: TB Tubes

 This device is normally supplied with Pb-free lead finish (second-level interconnect) as SS8021G, but can be supplied with a traditional lead finish (SS8021) upon request.

PIN CONFIGURATION

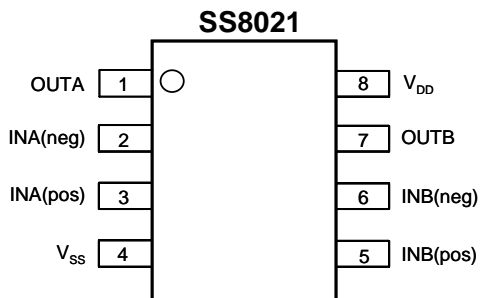

SYMBOL	PIN	DESCRIPTION
OUTA	1	output A
INA(neg)	2	inverting input A
INA(pos)	3	non-inverting input A
V_{SS}	4	negative supply
INB(pos)	5	non-inverting input B
INB(neg)	6	inverting input B
OUTB	7	output B
V_{DD}	8	positive supply

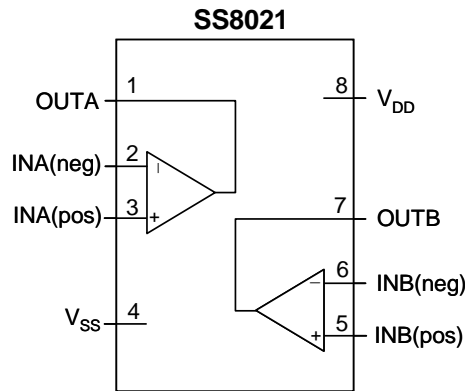
BLOCK DIAGRAM

ABSOLUTE MAXIMUM RATINGS (Note1)

SYMBOL	PARAMETER	CONDITION	MIN	MAX	UNIT
V_{DD}	Supply voltage		0	7.0	V
T_{stg}	Storage temperature		-65	+150	°C
T_{amb}	Operating ambient temperature		-40	+85	°C
ESD	ESD voltage	HBM	-	2	KV

Notes:

1. Absolute Maximum Ratings are limits beyond which damage to the device may occur.

THERMAL CHARACTERISTICS

SYMBOL	PARAMETER	VALUE	UNIT
$R_{th\ j-a}$	Thermal resistance from junction to ambient in free air SO8	240	°C/W

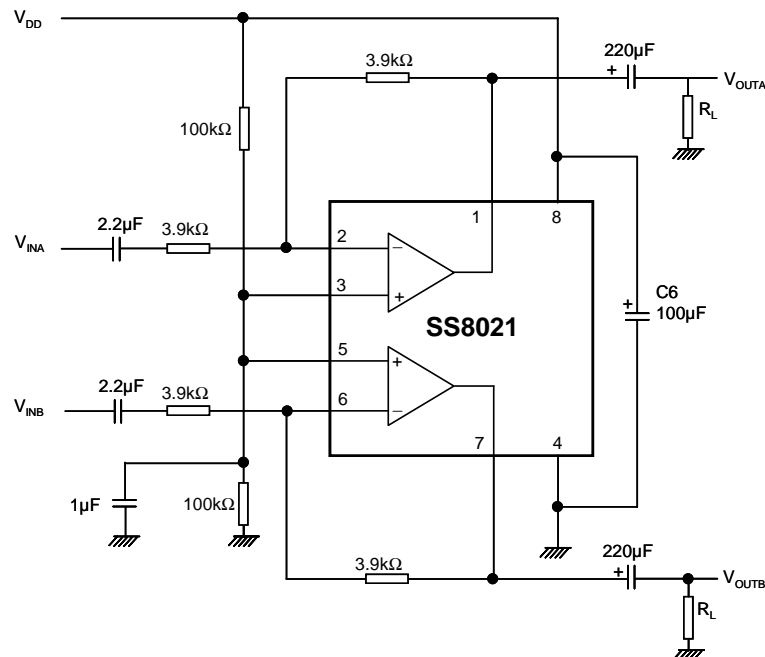
TEST AND APPLICATION INFORMATION

Fig.1 Measurement circuit for inverting application

ELECTRICAL CHARACTERISTICS
 $V_{DD} = 5V$; $V_{SS} = 0V$; $T_A = 25^\circ C$; $f_i = 1kHz$; $R_L = 32\Omega$ connected to $V_{DD}/2$; unless otherwise specified.

SYMBOL	PARAMETER	CONDITION	MIN	TYP	MAX	UNIT
Supplies						
V_{DD}	Supply voltage		3.0	5.0	6.5	V
	Single		3.0	5.0	6.5	V
	Dual		1.5	2.5	3.25	V
V_{SS}	Negative supply voltage		-1.5	-2.5	-3.25	V
I_{DD}	Supply current	no load	-	3.0	5.0	mA
P_{tot}	Total power dissipation	no load	-	15	25	mW
DC Characteristics						
$V_{I(OS)}$	Input offset voltage		-50	-	50	mV
V_{CM}	Common mode voltage		0	-	3.5	V
G_V	Open-loop voltage gain	$R_L = 5k\Omega$	60	90	-	dB
I_O	Maximum output current	THD+N < 0.1%	-	70	-	mA
R_O	Output resistance	closed-loop	-	0.1	-	Ω
$V_{DD}-V_{OH}$	Output Voltage Swing High	Sourcing current = 100mA	-	0.4	1	V
$V_{OL}-V_{SS}$	Output Voltage Swing Low	Sinking current = 100mA	-	0.5	1	V
PSRR	Power supply rejection ratio	$f_i = 1kHz$; $V_{ripple(rms)} = 100mV_{rms}$	-	70	-	dB
α_{CS}	Channel separation	$R_L=32\Omega, C_b=1\mu F, P_O=70mW$	-	65	-	dB
AC Characteristics						
THD	Total harmonic distortion	note 2	-	< 0.1	-	%
f_G	Unity gain frequency	open-loop; $R_L = 5k\Omega$	-	5	-	MHz
P_O	Maximum output power	note 1; $R_L = 16\Omega$; $f=1kHz$	-	125	-	mW
		note 1; $R_L = 32\Omega$; $f=1kHz$	-	75	-	mW

Notes:

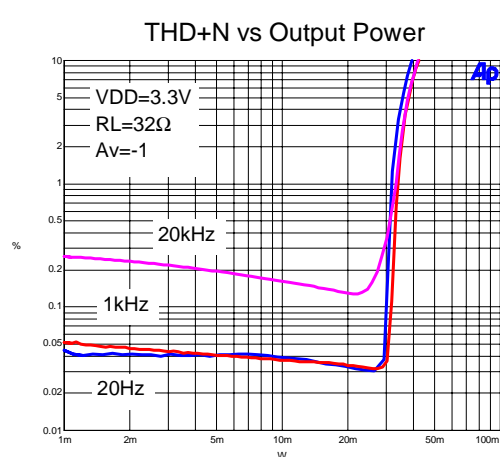
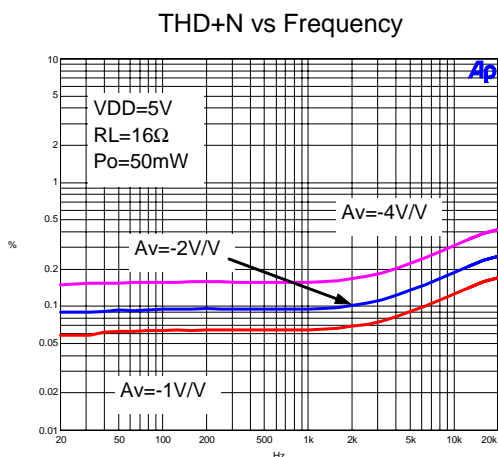
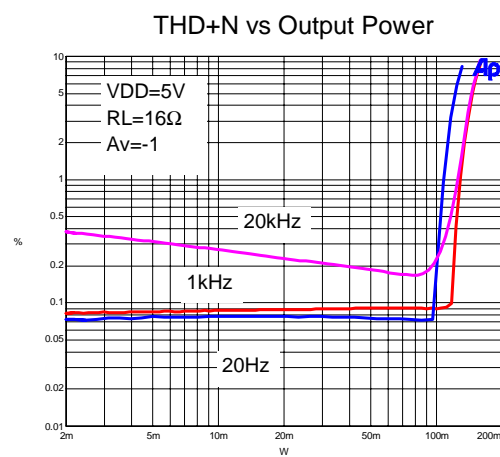
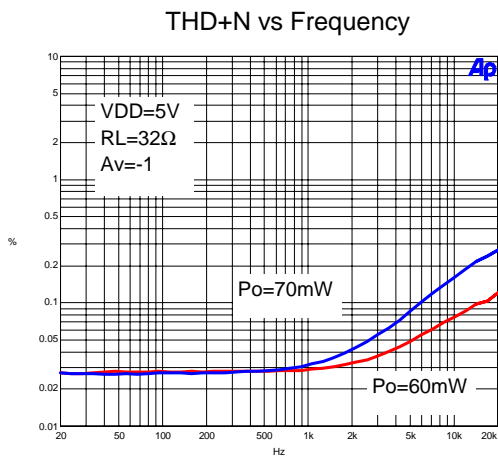
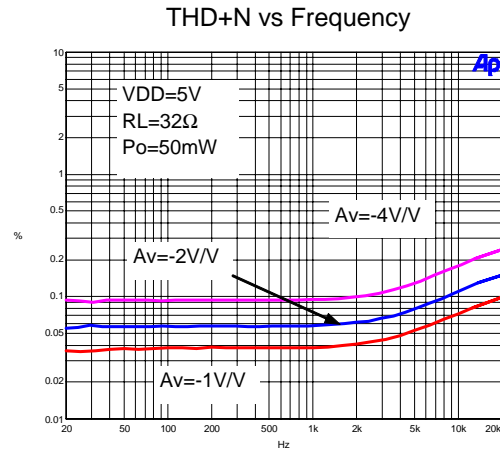
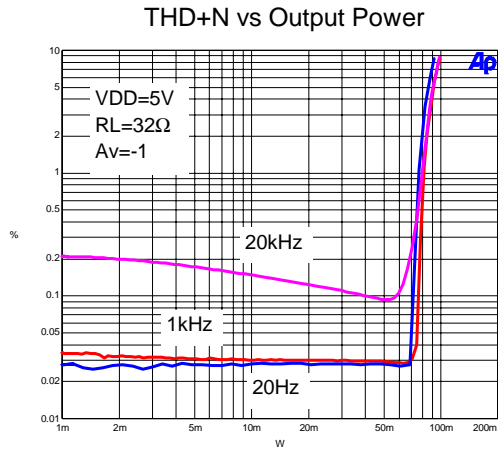
- Values are proportional to V_{DD} ; THD+N < 0.1%
- $V_{DD} = 5.0V$; $V_{O(P-P)} = 4.0V$ (at 0 dB)

Electrical Characteristics
 $C_{IN}=2.2\mu F, C_{OUT}=330\mu F, C_b=1\mu F, A_v=1, R_i=18k\Omega, R_f=18k\Omega ; A_v=-2, R_i=18k\Omega, R_f=36k\Omega ; A_v=-4, R_i=9k\Omega, R_f=36k\Omega, T_A=25^\circ C$

ELECTRICAL CHARACTERISTICS (continued)

THD+N vs Frequency

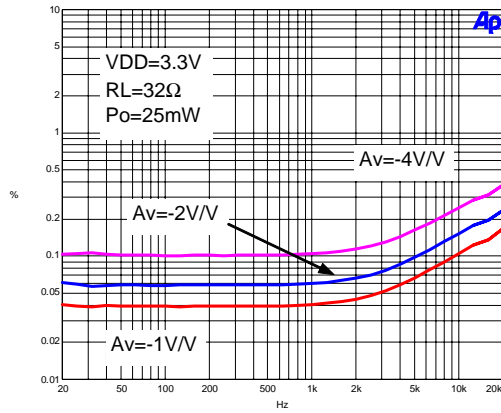

THD+N vs Output Power

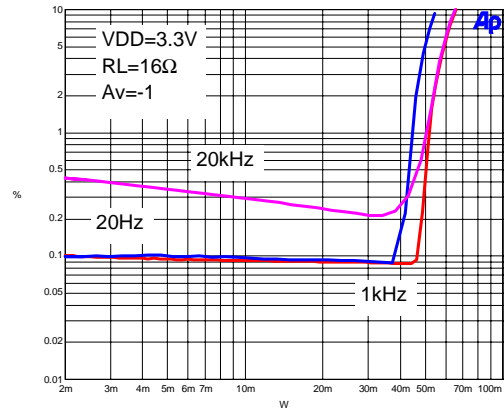

THD+N vs Frequency

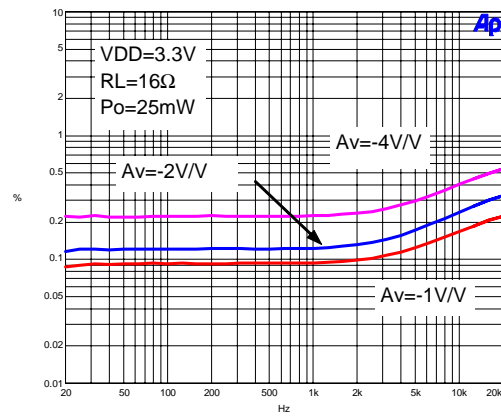

Output Noise

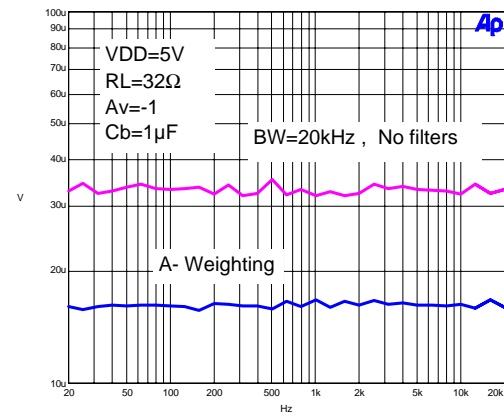

Channel Separation

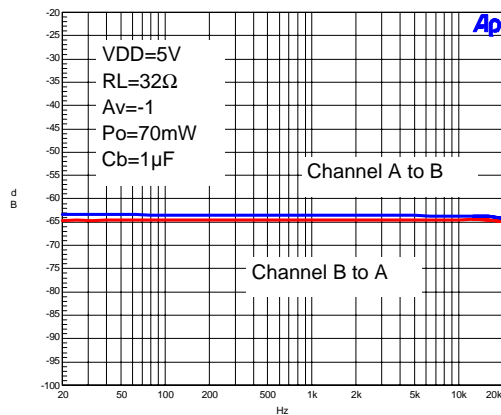

Power Supply Rejection Ratio

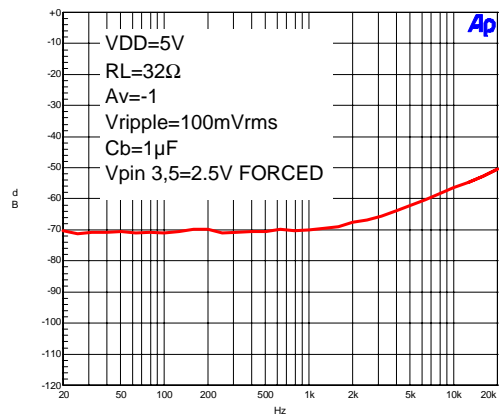

ELECTRICAL CHARACTERISTICS (continued)

Open Loop Frequency Response

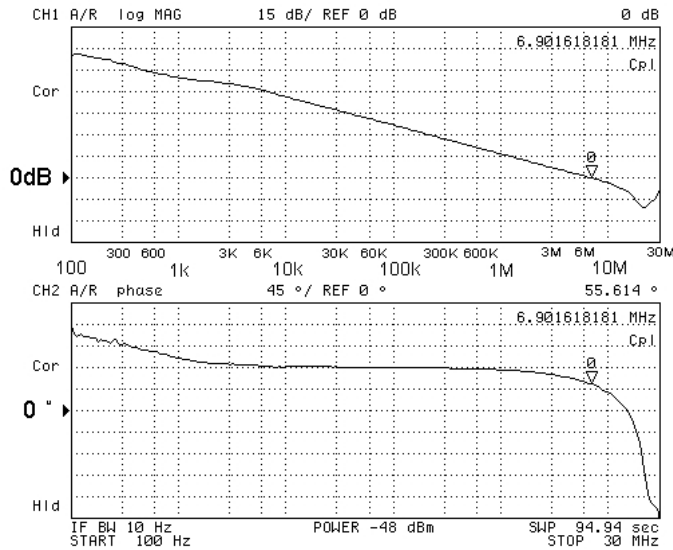

VDD=5V
RL=5K

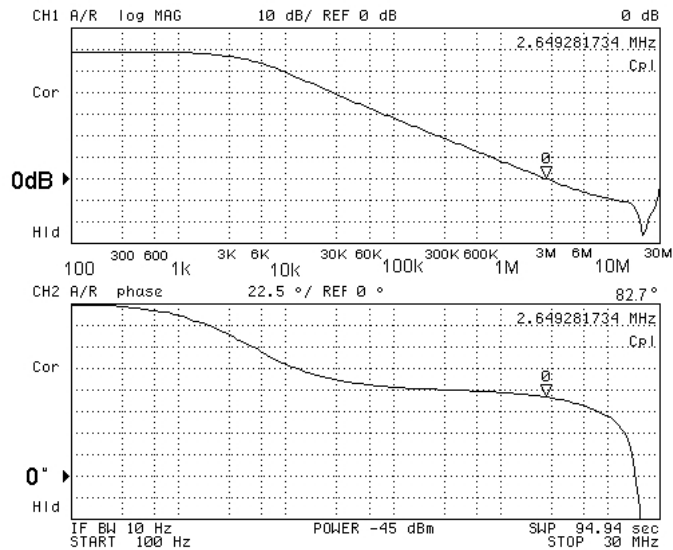

VDD=5V
RL=32 ohm

ELECTRICAL CHARACTERISTICS (continued)

Supply Current vs. Supply Voltage

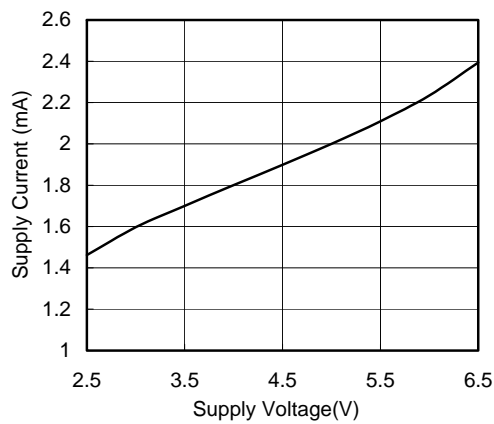

Supply Current vs. Temperature

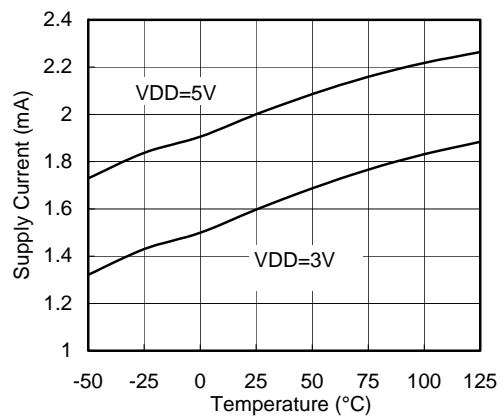

Offset Voltage vs. Supply Voltage

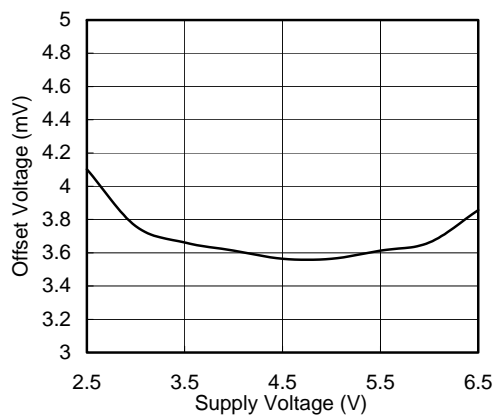

Offset Voltage vs. Temperature

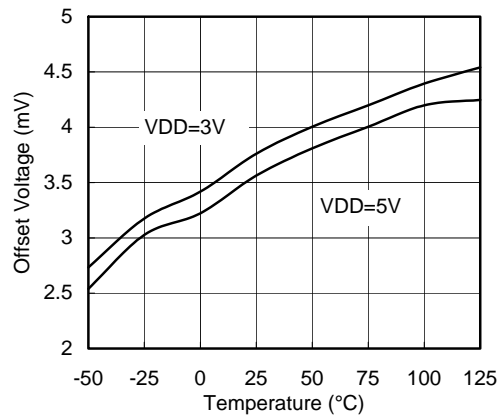
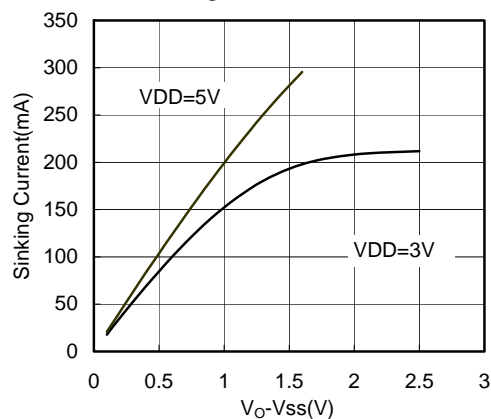
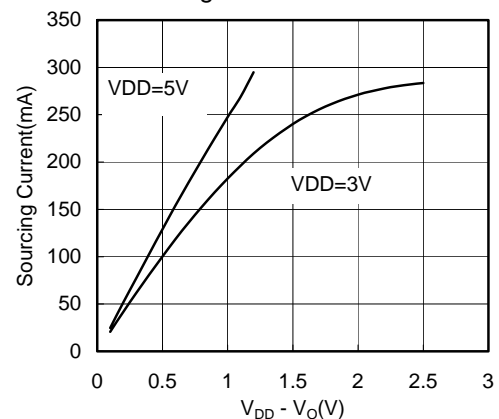
 Sinking Current vs. $V_o - V_{ss}$

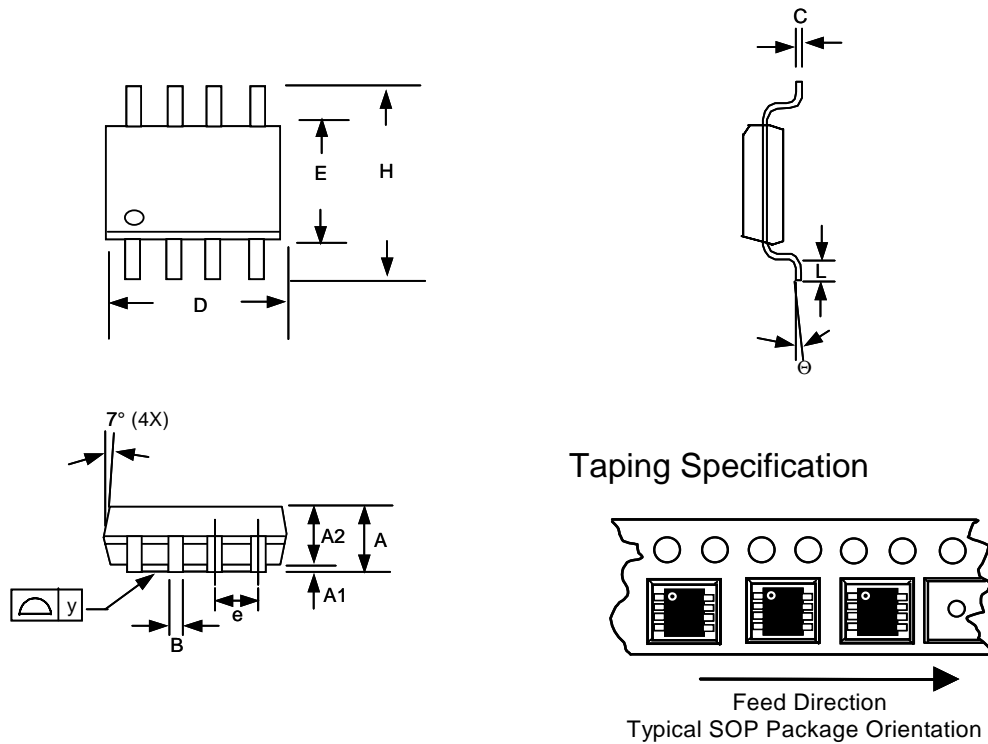
 Sourcing Current vs. $V_{DD} - V_o$

PHYSICAL DIMENSIONS

1. Package body sizes exclude mold flash and gate burrs
2. Dimension L is measured in gage plane
3. Tolerance 0.10mm unless otherwise specified
4. Controlling dimension is millimeter converted inch dimensions are not necessarily exact.

SYMBOL	DIMENSION IN MM			DIMENSION IN INCH		
	MIN.	NOM.	MAX.	MIN.	NOM.	MAX.
A	1.35	1.60	1.75	0.053	0.063	0.069
A1	0.10	-----	0.25	0.004	-----	0.010
A2	-----	1.45	-----	-----	0.057	-----
B	0.33	-----	0.51	0.013	-----	0.020
C	0.19	-----	0.25	0.007	-----	0.010
D	4.80	-----	5.00	0.189	-----	0.197
E	3.80	-----	4.00	0.150	-----	0.157
e	-----	1.27	-----	-----	0.050	-----
H	5.80	-----	6.20	0.228	-----	0.244
L	0.40	-----	1.27	0.016	-----	0.050
y	-----	-----	0.10	-----	-----	0.004
Θ	0°	-----	8°	0°	-----	8°

Information furnished by Silicon Standard Corporation is believed to be accurate and reliable. However, Silicon Standard Corporation makes no guarantee or warranty, express or implied, as to the reliability, accuracy, timeliness or completeness of such information and assumes no responsibility for its use, or for infringement of any patent or other intellectual property rights of third parties that may result from its use. Silicon Standard reserves the right to make changes as it deems necessary to any products described herein for any reason, including without limitation enhancement in reliability, functionality or design. No license is granted, whether expressly or by implication, in relation to the use of any products described herein or to the use of any information provided herein, under any patent or other intellectual property rights of Silicon Standard Corporation or any third parties.