

3.3V 1A Low Dropout Regulator

FEATURES

- Dropout voltage typically 0.8V @ $I_O = 1A$
- Output current in excess of 1A
- Output voltage accuracy $\pm 2\%$
- Quiescent current, typically 600 μ A
- Internal short circuit current limit
- Internal over temperature protection

APPLICATIONS

- CD-R/W
- ADSL
- Cable Modem
- Set-Top-Box
- LAN switch/Hub
- Router
- DVD-R/W

Pb-free, RoHS compliant.

ORDERING INFORMATION

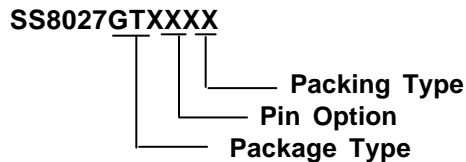

PACKAGE TYPE

- GT3 : TO 220 Pb-free
- GT4 : TO 252 Pb-free
- GT5 : TO 263 Pb-free
- GT6 : SOT 223 Pb-free

PIN OPTION

| | 1 | 2 | 3 |
|-----|-----------|-----------|-----------|
| 1 : | V_{OUT} | GND | V_{IN} |
| 2 : | V_{OUT} | V_{IN} | GND |
| 3 : | GND | V_{OUT} | V_{IN} |
| 4 : | GND | V_{IN} | V_{OUT} |
| 5 : | V_{IN} | GND | V_{OUT} |
| 6 : | V_{IN} | V_{OUT} | GND |

PACKING

- TR : Tape & Reel
- TB : Tube

TYPICAL APPLICATION

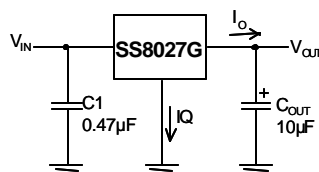

PIN CONFIGURATION

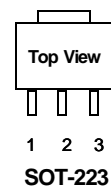
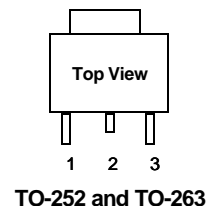
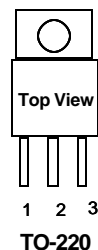

Absolute Maximum Ratings

(Note 1)

| | |
|---|---------------------------------|
| Input Voltage..... | 10V |
| Power Dissipation Internally Limited | (Note 2) |
| Maximum Junction Temperature..... | 150°C |
| Storage Temperature Range..... | -65°C ≤ T _J ≤ +150°C |
| Lead Temperature, Time for Wave Soldering | |
| TO 220, TO 263 Package..... | 260°C, 10s |
| TO 252, SOT 223 Package..... | 260°C, 4s |
| Continuous Power Dissipation (T _A = +25°C) | |
| SOT 223 ⁽¹⁾ | 0.8W |
| TO 252 ⁽¹⁾ | 1.0W |
| TO 263 ⁽¹⁾ | 1.6W |
| TO 220 ⁽¹⁾ | 2.0W |

 Note ⁽¹⁾: See Recommended Minimum Footprint

Operating Conditions

(Note 1)

| | |
|------------------------|--------------------------------|
| Input Voltage..... | 4V~7V |
| Temperature Range..... | -40°C ≤ T _J ≤ 125°C |

Electrical Characteristics
V_{IN} = 5V, I_O = 1A, C_{IN} = 1μF, C_{OUT} = 10μF, All specifications apply for T_A = T_J = 25°C. [Note 3]

| PARAMETER | CONDITIONS | MIN | TYP | MAX | UNITS |
|-----------------------|--|-------|-----|-------|-------|
| Output Voltage | 50mA ≤ I _O ≤ 1A | 3.234 | 3.3 | 3.366 | V |
| Line Regulation | 4V ≤ V _{IN} ≤ 7V, I _O = 10mA | | 20 | 30 | mV |
| Load Regulation | 50mA ≤ I _O ≤ 1A | | 30 | 50 | mV |
| Output Impedance | 200mA DC and 100mA AC, f _o = 120Hz | | 100 | | mΩ |
| Quiescent Current | V _{IN} = 5V | | 0.6 | | mA |
| Ripple Rejection | f _r = 120Hz, 1V _{P-P} , I _O = 100mA | | 42 | | dB |
| Dropout Voltage | I _O = 1A | | 0.8 | | V |
| | I _O = 100mA | | 200 | | mV |
| Short Circuit Current | | 1.6 | 1.9 | | A |
| Over Temperature | | | 125 | | °C |

Note 1: Absolute Maximum Ratings are limits beyond which damage to the device may occur. Operating Conditions are conditions under which the device functions but the specifications might not be guaranteed. For guaranteed specifications and test conditions see the Electrical Characteristics.

Note 2: The maximum power dissipation is a function of the maximum junction temperature, T_{Jmax}, total thermal resistance, θ_{JA}, and ambient temperature T_A. The maximum allowable power dissipation at any ambient temperature is T_{Jmax} - T_A / θ_{JA}. If this dissipation is exceeded, the die temperature will rise above 150°C and IC will go into thermal shutdown. For the SS8027G in the SOT-223 package, θ_{JA} is 156°C/W; in the TO-252 package, θ_{JA} is 125°C/W; in the TO-263 package, θ_{JA} is 75°C/W, and in the TO-220 package, θ_{JA} is 60°C/W (no heat sink). [See Recommended Minimum Footprint] If the TO-220 package is used with a heat sink, θ_{JA} is the sum of the package thermal resistance junction-to-case (θ_{JC}) of 3°C/W and the thermal resistance added by the heat sink and thermal interface. The thermal resistance can be reduced by increasing the P.C. board copper area thermally connected to the package. The safe operation area of SOT-223, TO-252, TO-263 or TO-220 packages can be seen in "Typical Performance Characteristics" (Safe Operating Area).

Note3: Low duty-cycle pulse techniques are used during test to maintain the junction temperature as close to ambient temperature as possible.

Note4: The output capacitor should be a tantalum or aluminum type.

Definitions

Dropout Voltage

The input/output voltage differential at which the regulator output no longer maintains regulation against further reductions in input voltage. Measured when the output drops 100mV below its nominal value, dropout voltage is affected by junction temperature, load current and minimum input supply requirements.

Line Regulation

The change in output voltage for a change in input voltage. The measurement is made under conditions of low dissipation or by using pulse techniques, so that average chip temperature is not significantly affected.

Load Regulation

The change in output voltage for a change in load current at constant chip temperature. The measurement is made under conditions of low dissipation or by using pulse techniques, so that average chip temperature is not significantly affected.

Maximum Power Dissipation

The maximum total device dissipation for which the regulator will operate within specifications.

Quiescent Bias Current

Current which is used to operate the regulator chip and is not delivered to the load.

Typical Performance Characteristics

($V_{IN}=5V$, $C_{IN}=1\mu F$, $C_{OUT}=10\mu F$, $T_A=25^\circ C$, unless otherwise noted.)

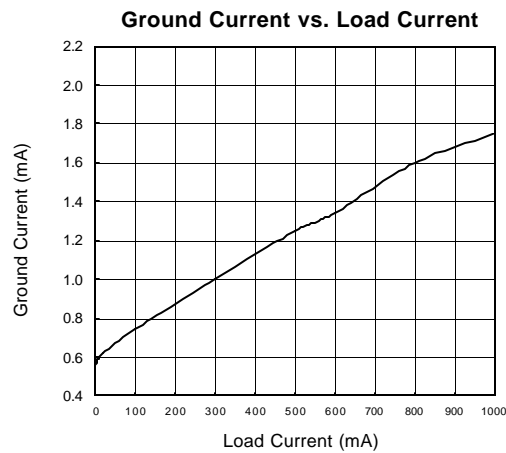
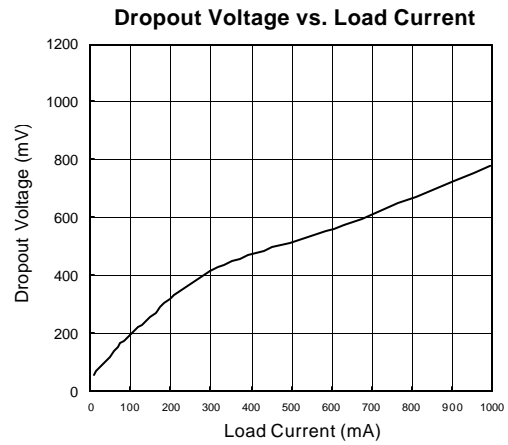
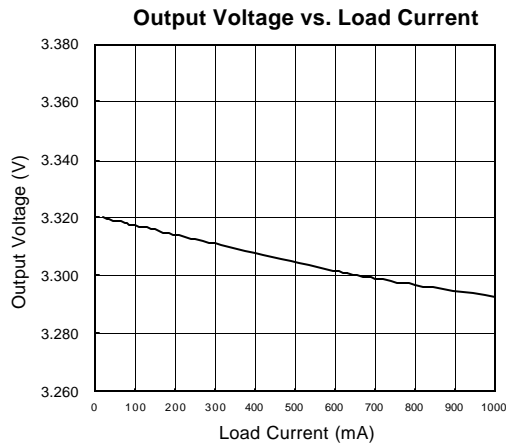
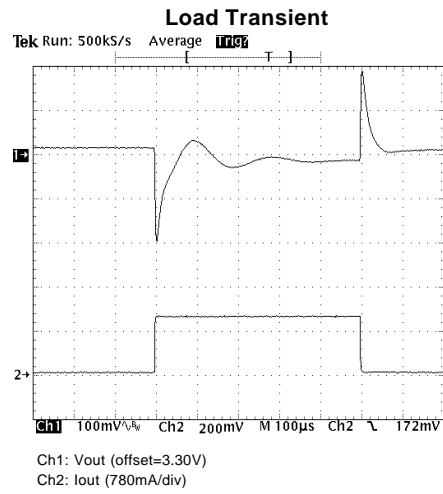
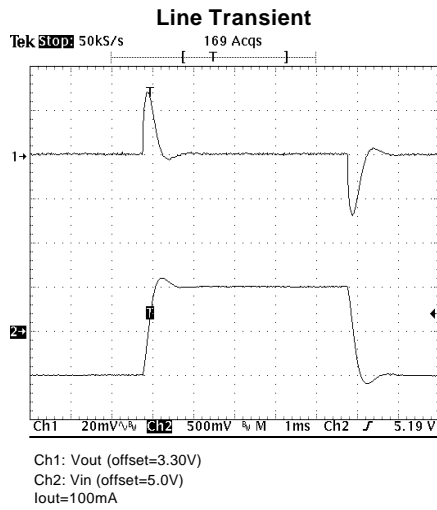

Typical Performance Characteristics (continued)

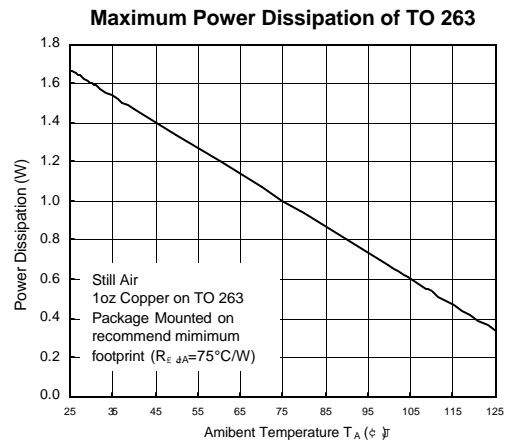
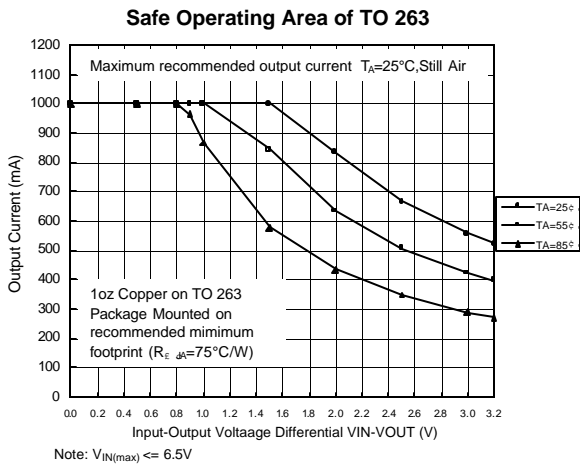
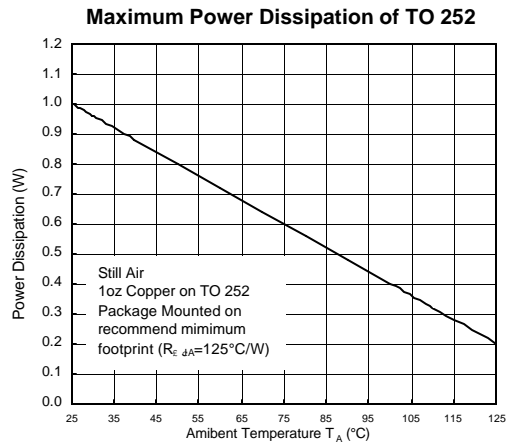
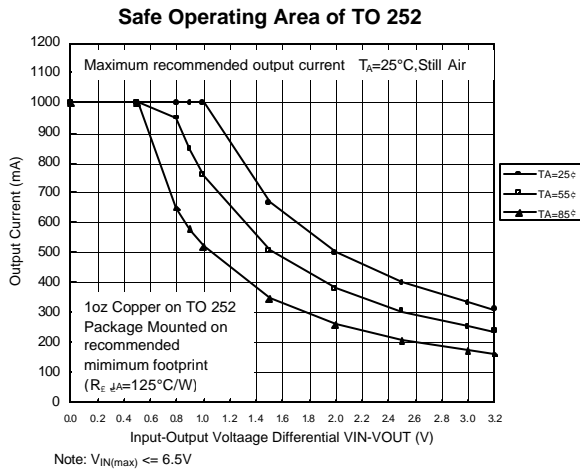
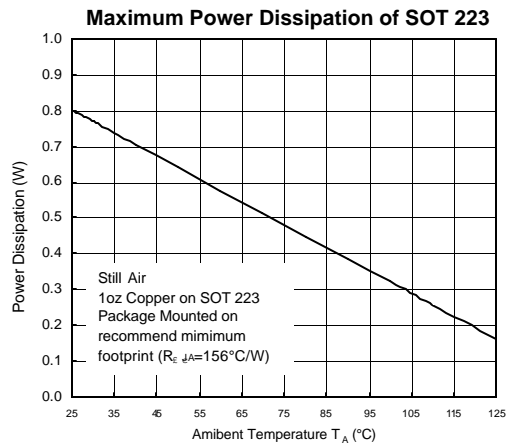
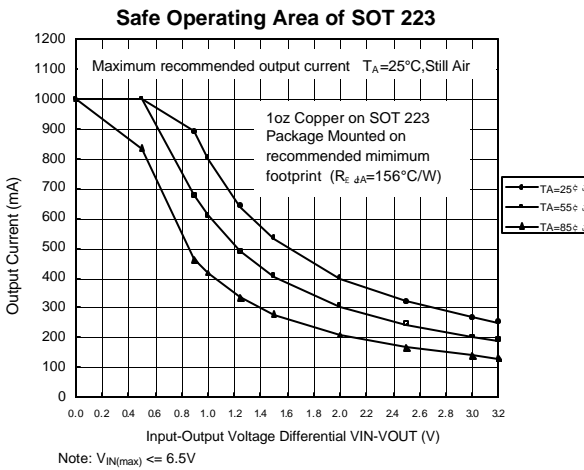

Typical Performance Characteristics (continued)

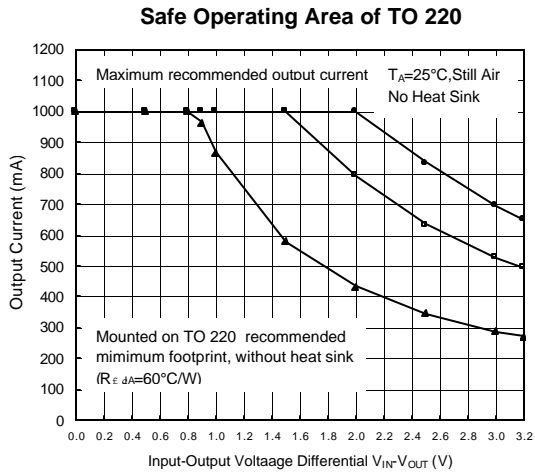

Note: $V_{IN(max)} \leq 6.5\text{V}$

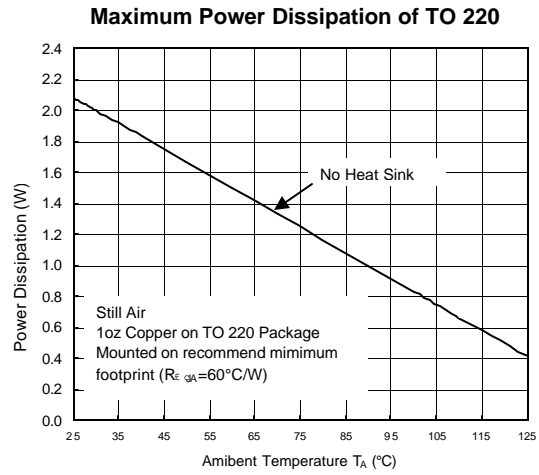

Recommended Minimum Footprint

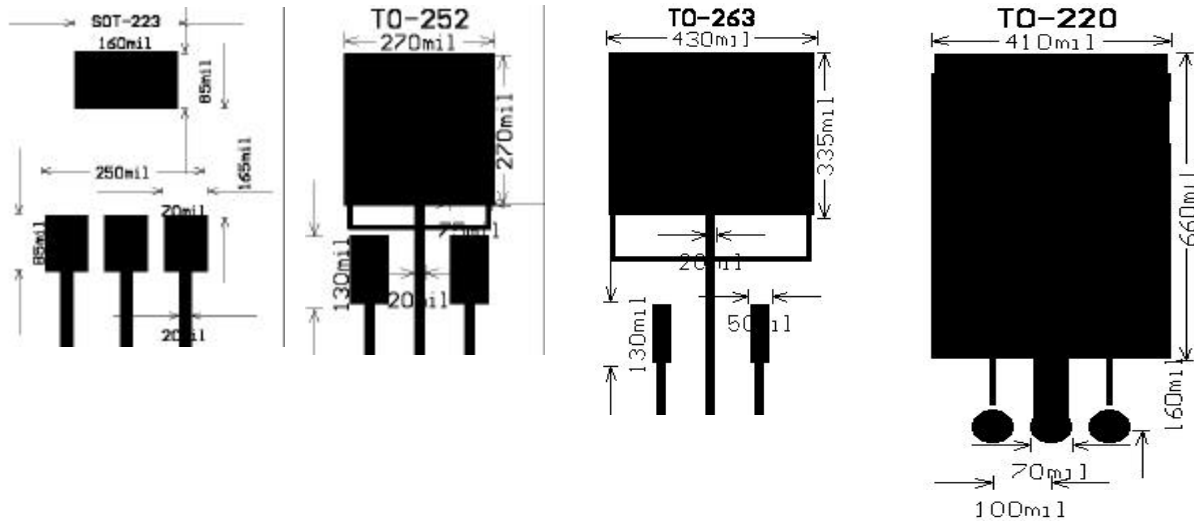

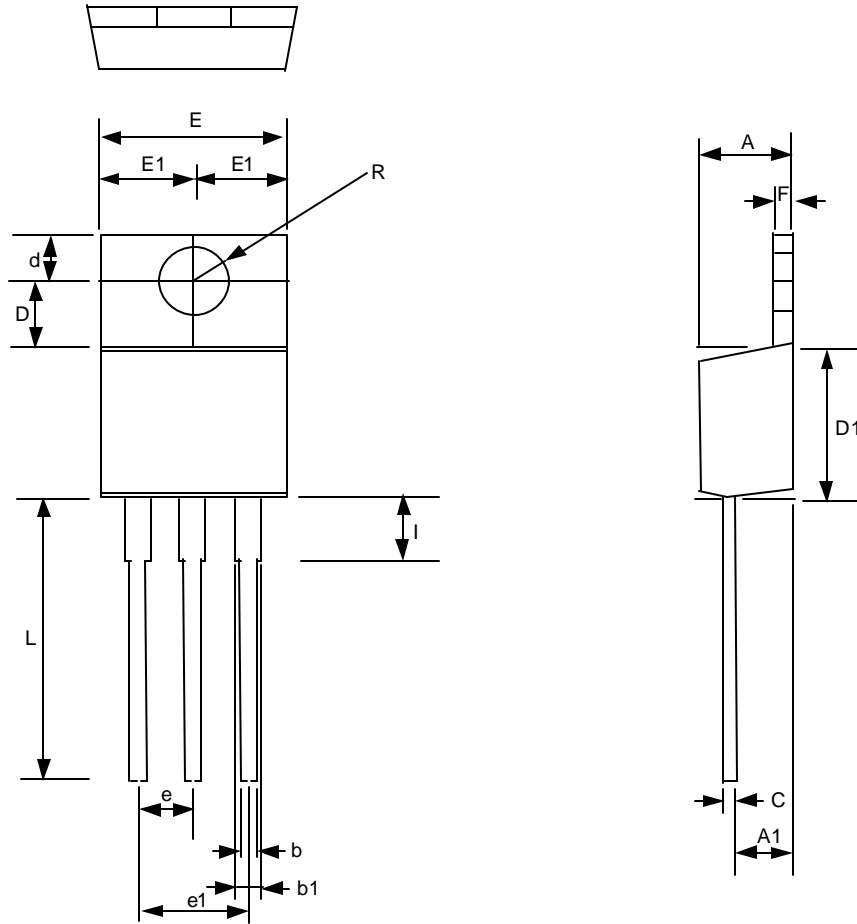
Package Information

TO-220 (GT3) Package

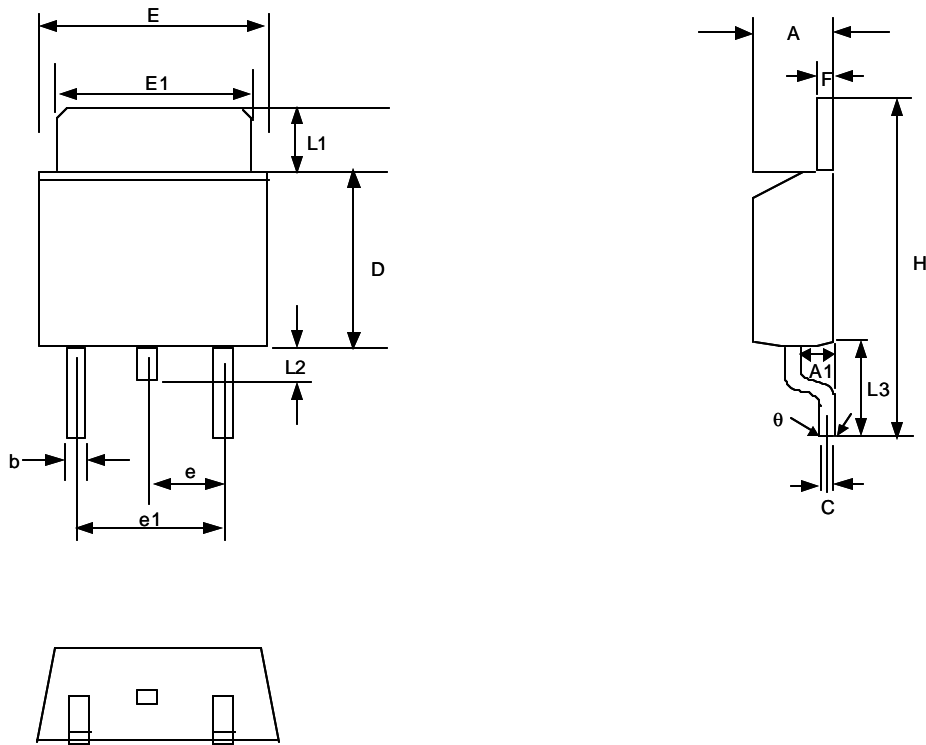
| SYMBOLS | MILLIMETERS | | INCHES | |
|---------|-------------|--------|--------|-------|
| | MIN | MAX | MIN | MAX |
| A | 4.318 | 4.826 | 0.170 | 0.190 |
| A1 | 2.46 | 2.72 | 0.097 | 0.107 |
| b | 0.69 | 0.94 | 0.027 | 0.037 |
| b1 | 1.143 | 1.397 | 0.045 | 0.055 |
| C | 0.304 | 0.460 | 0.012 | 0.018 |
| D | 3.429 | 3.683 | 0.135 | 0.145 |
| D1 | 8.53 | 9.04 | 0.336 | 0.356 |
| d | 2.62 | 2.87 | 0.103 | 0.113 |
| E | 9.906 | 10.40 | 0.390 | 0.410 |
| E1 | 2.84 | 5.13 | 0.112 | 0.202 |
| e | 2.29 | 2.79 | 0.090 | 0.110 |
| e1 | 4.83 | 5.33 | 0.190 | 0.210 |
| F | 1.143 | 1.397 | 0.045 | 0.055 |
| I | 3.454 | 3.962 | 0.136 | 0.156 |
| L | 13.589 | 14.351 | 0.535 | 0.565 |

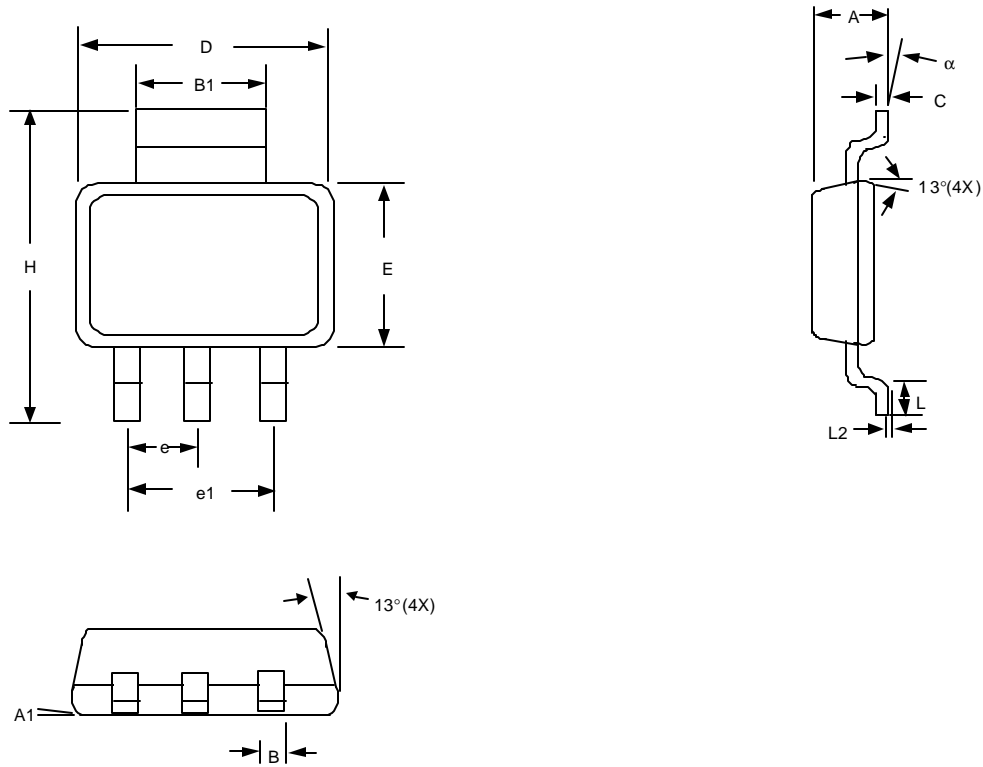

TO-252 (GT4) Package

| SYMBOL | MILLIMETERS | | INCHES | |
|--------|-------------|-------|---------|-------|
| | MIN. | MAX. | MIN. | MAX. |
| A | 2.19 | 2.38 | 0.086 | 0.094 |
| A1 | 0.89 | 1.27 | 0.035 | 0.050 |
| b | 0.64 | 0.89 | 0.025 | 0.035 |
| C | 0.46 | 0.58 | 0.018 | 0.023 |
| D | 5.97 | 6.22 | 0.235 | 0.245 |
| E | 6.35 | 6.73 | 0.250 | 0.265 |
| E1 | 5.21 | 5.46 | 0.205 | 0.215 |
| e | 2.26BSC | | 0.09BSC | |
| e1 | 3.96 | 5.18 | 0.156 | 0.204 |
| F | 0.46 | 0.58 | 0.018 | 0.023 |
| L1 | 0.89 | 2.03 | 0.035 | 0.080 |
| L2 | 0.64 | 1.02 | 0.025 | 0.040 |
| L3 | 2.40 | 2.80 | 0.095 | 0.110 |
| H | 9.40 | 10.40 | 0.370 | 0.410 |
| θ | 0° | 4° | 0° | 4° |

SOT-223 (GT6) Package

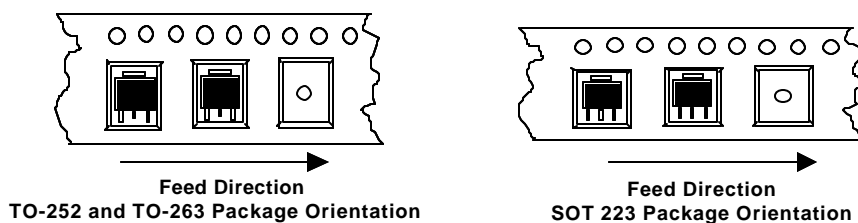
| SYMBOLS | MILLIMETERS | | INCHES | |
|---------|-------------|------|------------|--------|
| | MIN | MAX | MIN | MAX |
| A | 1.55 | 1.80 | 0.061 | 0.071 |
| A1 | 0.02 | 0.12 | 0.0008 | 0.0047 |
| B | 0.60 | 0.80 | 0.024 | 0.031 |
| B1 | 2.90 | 3.10 | 0.114 | 0.122 |
| C | 0.24 | 0.32 | 0.009 | 0.013 |
| D | 6.30 | 6.70 | 0.248 | 0.264 |
| E | 3.30 | 3.70 | 0.130 | 0.146 |
| e | 2.30 BSC | | 0.090 BSC | |
| e1 | 4.60 BSC | | 0.181 BSC | |
| H | 6.70 | 7.30 | 0.264 | 0.287 |
| L | 0.90 MIN | | 0.036 MIN | |
| L2 | 0.06 BSC | | 0.0024 BSC | |
| a | 0° | 10° | 0° | 10° |

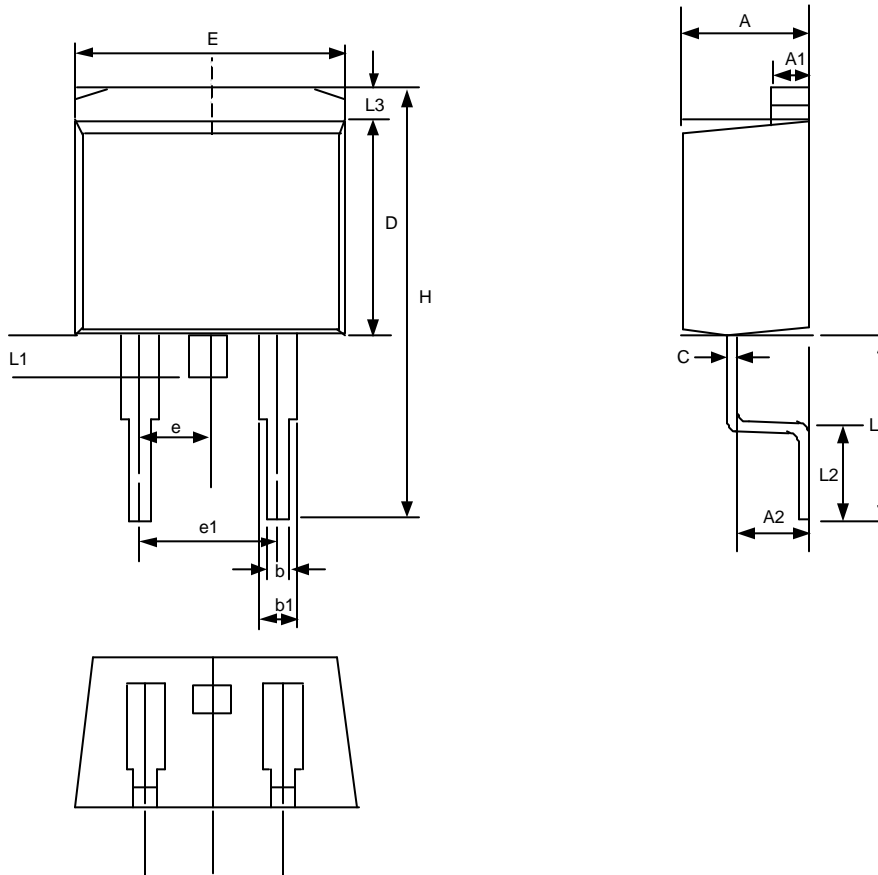
Package Orientation



TO-263 (GT5) Package

| SYMBOLS | MILLIMETERS | | INCHES | |
|---------|-------------|-------|----------|-------|
| | MIN | MAX | MIN | MAX |
| A | 4.30 | 4.70 | 0.169 | 0.185 |
| A1 | 1.22 | 1.32 | 0.048 | 0.055 |
| A2 | 2.45 | 2.69 | 0.104 | 0.106 |
| b | 0.69 | 0.94 | 0.027 | 0.037 |
| b1 | 1.22 | 1.40 | 0.048 | 0.055 |
| C | 0.36 | 0.56 | 0.014 | 0.022 |
| D | 8.64 | 9.652 | 0.340 | 0.380 |
| E | 9.70 | 10.54 | 0.382 | 0.415 |
| e | 2.29 | 2.79 | 0.090 | 0.110 |
| e1 | 4.83 | 5.33 | 0.190 | 0.210 |
| H | 14.60 | 15.78 | 0.575 | 0.625 |
| L | 4.70 | 5.84 | 0.185 | 0.230 |
| L1 | 1.20 | 1.778 | 0.047 | 0.070 |
| L2 | 2.24 | 2.84 | 0.088 | 0.111 |
| L3 | 1.40MAX | | 0.055MAX | |

Information furnished by Silicon Standard Corporation is believed to be accurate and reliable. However, Silicon Standard Corporation makes no guarantee or warranty, express or implied, as to the reliability, accuracy, timeliness or completeness of such information and assumes no responsibility for its use, or for infringement of any patent or other intellectual property rights of third parties that may result from its use. Silicon Standard reserves the right to make changes as it deems necessary to any products described herein for any reason, including without limitation enhancement in reliability, functionality or design. No license is granted, whether expressly or by implication, in relation to the use of any products described herein or to the use of any information provided herein, under any patent or other intellectual property rights of Silicon Standard Corporation or any third parties.