

Micro-Power Step-up DC/DC Converter

FEATURES

- Configurable output voltage up to 28V
- Quiescent current of 20 μ A
- Shutdown current <1 μ A
- Shutdown-pin current <1 μ A
- Supply range from 2.5V to 6.5V
- Low $V_{DS(on)}$: 250mV (I_{SW} =300mA)
- Tiny SOT23-5 package

APPLICATIONS

- STN/TFT LCD Bias
- Personal Digital Assistants (PDAs)
- Handheld Computers
- Digital Still Cameras
- Cellular Phones
- WebPad
- White LED Driver
- Local 3V to 5V Conversion

DESCRIPTION

The SS8051 boost converter is designed for small to medium size LCD panels requiring high bias voltages.

With a typical quiescent current of 20 μ A and a supply voltage range of 2.5V to 6.5V, it is suitable for battery powered portable applications, such as PDAs and handheld computers. When the SS8051 goes into shutdown mode, it consumes less than 1 μ A.

Furthermore, with a 350mA current limit, 500ns fixed minimum off-time and tiny SOT23-5 package, the SS8051 can be used with smaller inductors and other surface-mount components to minimize the required PCB footprint in space-conscious applications.

To control the SS8051, no other external current is needed for the shutdown pin, which typically consumes less than 1 μ A over the full supply range.

TYPICAL APPLICATION CIRCUIT

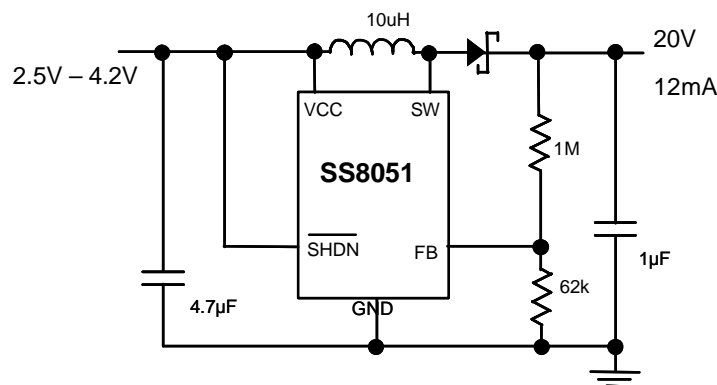

ORDERING INFORMATION

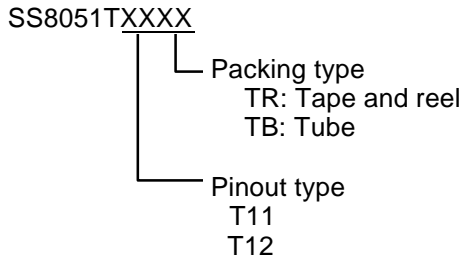

Example: SS8051T12TR
T12 pin configuration shipped in
tape and reel packing

PIN CONFIGURATION

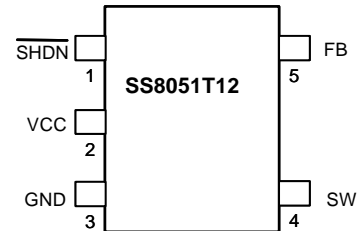
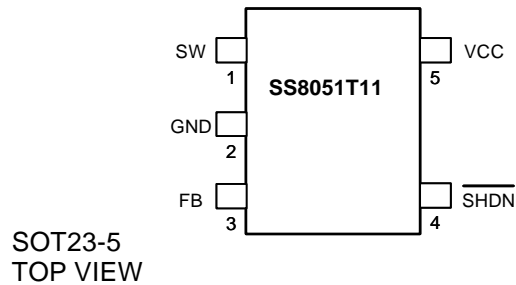

PIN DESCRIPTION

NAME	FUNCTION
SW	Switch Pin. The drain of the internal NMOS power switch. Connect this pin to inductor.
GND	Ground.
FB	Feedback Pin. Set the output voltage by selecting values for R1 and R2 (see Block Diagram): $R1 = R2 \left(\frac{V_{OUT}}{1.2} - 1 \right)$
$\overline{\text{SHDN}}$	Active-Low Shutdown Pin. Tie this pin to logic-high to enable the device or tie it to logic-low to turn the device off.
VCC	Input Supply Pin. Bypass this pin with a capacitor as close to the device as possible.

ABSOLUTE MAXIMUM RATINGS

SW to GND.....-0.3V to +30V
 FB to GND.....-0.3V to V_{CC}
 VCC, $\overline{\text{SHDN}}$ to GND.....-0.3V to +7V

Operating Temperature Range..... -40°C to 85°C
 Maximum Operating Junction Temperature..... +125°C
 Storage Temperature Range -65°C to 150°C
 Maximum Lead Temperature (Soldering, 10sec)..... +300°C

ELECTRICAL CHARACTERISTICS
($V_{CC} = 3.6V$, $V_{\overline{SHDN}} = 3.6V$, $T_A = 25^\circ C$)

PARAMETER	CONDITIONS	MIN	TYP	MAX	UNITS
Input Voltage Range		2.5		6.5	V
Quiescent Current	Not switching		20	30	μA
	$V_{\overline{SHDN}} = 0V$		0.1	1	μA
FB Comparator Trip Point		1.18	1.2	1.22	V
Output Voltage Line Regulation	$2.5V < V_{IN} < 6.5V$		-0.05		%/V
FB Pin Bias Current (Note 2)	$V_{FB} = 1.2V$		30	80	nA
Switch Off Time	$V_{FB} > 1V$		500		ns
	$V_{FB} < 0.6V$		1.6		μs
Switch $V_{DS(ON)}$	$I_{SW} = 300mA$		250	350	mV
Switch Current Limit		300	350	400	mA
\overline{SHDN} Pin Current			0.1	1	μA
\overline{SHDN} Input Voltage High		0.9			V
\overline{SHDN} Input Voltage Low				0.25	V
Switch Leakage Current	Switch off, $V_{SW} = 28V$		0.01	5	μA

Note 1: The SS8051 is guaranteed to meet performance specifications from $0^\circ C$ to $85^\circ C$. Specifications over the $-40^\circ C$ to $85^\circ C$ operating temperature range are assured by design, characterization and correlation with statistical process controls.

Note 2: Bias current flows into the FB pin.

TYPICAL PERFORMANCE CHARACTERISTICS

($V_{CC} = +3.6V$, $V_{SHDN} = +3.6V$, $L=10\mu H$, $T_A=25^\circ C$, unless otherwise noted.)

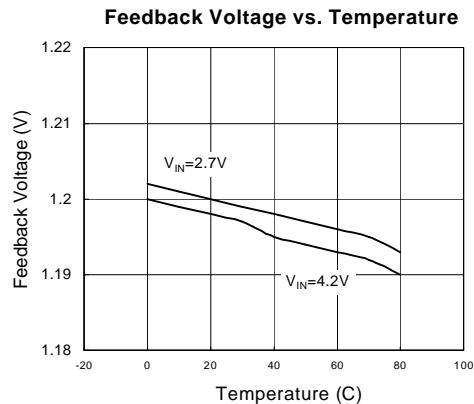
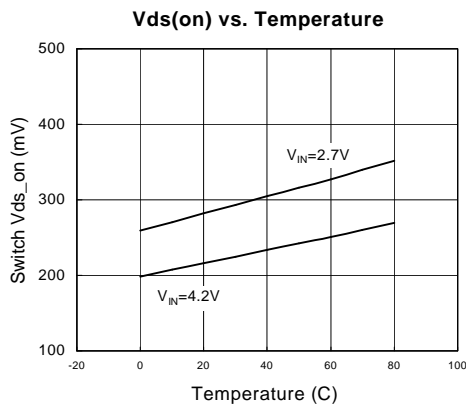
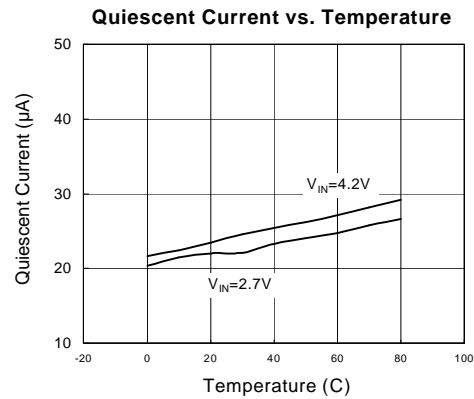
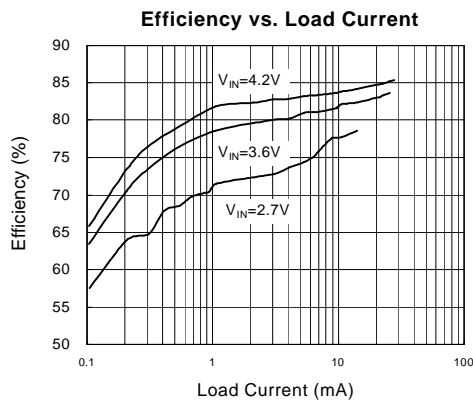
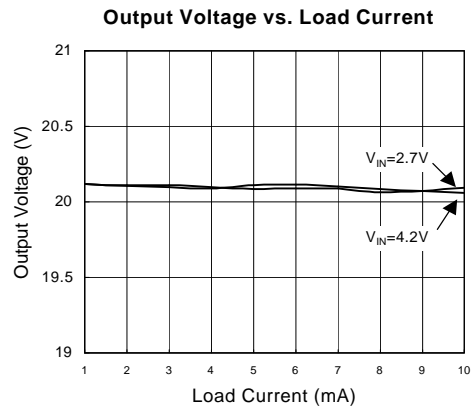
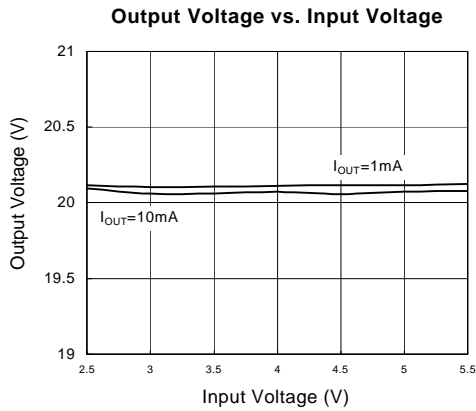

TYPICAL PERFORMANCE CHARACTERISTICS (cont.)

FB Bias Current vs. Temperature

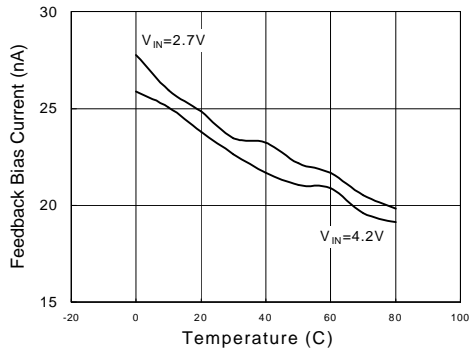

Switch Current Limit vs. Temperature

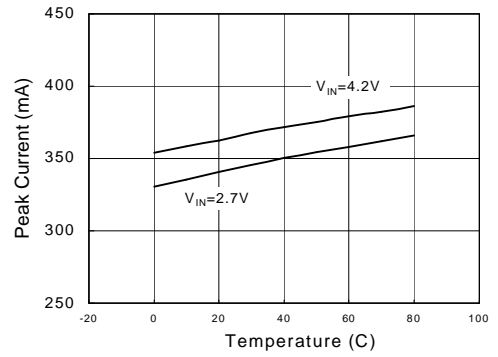

Line Transient

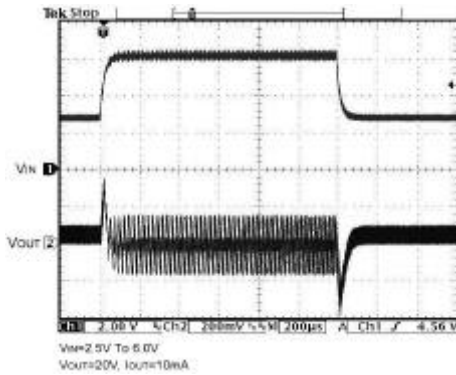

Load Transient

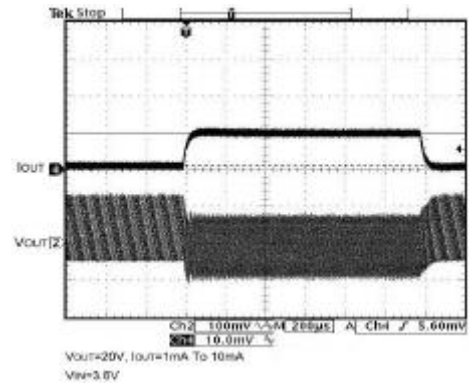

Here, $V_D = 0.4V$ (Schottky diode voltage), $I_{LIM} = 350mA$ and $t_{OFF} = 500ns$. A larger value can be used to slightly increase the available output current, but limit it to about twice the calculated value. When too large an inductor is used, the output voltage ripple will increase without providing much additional output current. In conditions of varying V_{IN} , such as battery power applications, use the minimum V_{IN} value in the above equation. A smaller value can be used to give smaller physical size, but overshoot of the inductor current will occur (see Current Limit Overshoot section).

Inductor Selection – SEPIC Regulator

For a SEPIC regulator using the SS8051, the approximate inductance value can be calculated using the formula below. As for the boost inductor selection, a larger or smaller value can be used.

$$L = 2 \left(\frac{V_{OUT} + V_D}{I_{LIM}} \right) \times t_{OFF}$$

Current Limit Overshoot

The SS8051 uses a constant off-time control scheme; the MOSFET is turned off after the 350mA current limit is reached. When the current limit is reached and the MOSFET actually turns off, there is a 100ns delay time. During this time, the inductor current exceeds the current limit by a small amount. The formula below can calculate the peak inductor current.

$$I_{PEAK} = I_{LIM} + \left(\frac{V_{IN(MAX)} - V_{SAT}}{L} \right) \times 100ns$$

Here, $V_{SAT} = 0.25V$ (switch saturation voltage). For systems with high input voltages and smaller inductance values, the current overshoot will be most apparent. This overshoot can be useful as it helps increase the amount of available output current. By using a small inductance value, the current limit overshoot can be quite high. Even though it is internally current limited to 350mA, the internal MOSFET of the SS8051 can handle larger currents

without any problem, but the total efficiency will suffer. For best performance, the I_{PEAK} is best kept below 500mA.

Capacitor Selection

Low ESR (Equivalent Series Resistance) capacitors should be used at the output to minimize the output ripple voltage and the peak-to-peak transient voltage. Multilayer ceramic capacitors (MLCC) are the best choice, as they have a very low ESR and are available in very small packages. Their small size makes them a good match with the SS8051's SOT-23 package. If solid tantalum capacitors (like the AVX TPS, Sprague 593D families) or OS-CON capacitors are used, they will occupy more volume than ceramic ones and the higher ESR increases the output ripple voltage. It is important to use a capacitor with a sufficient voltage rating.

A low ESR surface-mount ceramic capacitor also makes a good selection for the input bypass capacitor, which should be placed as close as possible to the SS8051. A 4.7 μ F input capacitor is sufficient for most applications.

Diode Selection

For most SS8051 applications, the high switching frequency requires high-speed Schottky diodes, such as the Motorola MBR0530 (0.5A, 30V) with their low forward voltage drop and fast switching speed. Many different manufacturers make equivalent parts, but make sure that the component is rated for at least 0.35A. To achieve high efficiency, the average current rating of the Schottky diodes should be greater than the peak switching current. Choose a reverse breakdown voltage greater than the output voltage.

Lowering Output Ripple Voltage

The SS8051 supplies energy to the load in bursts by ramping up the inductor current, then delivering that current to the load. Using low ESR capacitors will help

minimize the output ripple voltage, but proper selection of the inductor and the output capacitor also plays a big role. If a larger inductance value or a smaller capacitance value is used, the output ripple voltage will increase because the capacitor will be slightly overcharged each burst cycle. To reduce the

output ripple, increase the output capacitance value, or add a 10pF feed-forward capacitor in the feedback network of the SS8051 (see the circuits in the Typical Applications section). To add this small inexpensive 10pF capacitor will greatly reduce the output voltage ripple.

TYPICAL APPLICATION CIRCUITS

Boost Converter

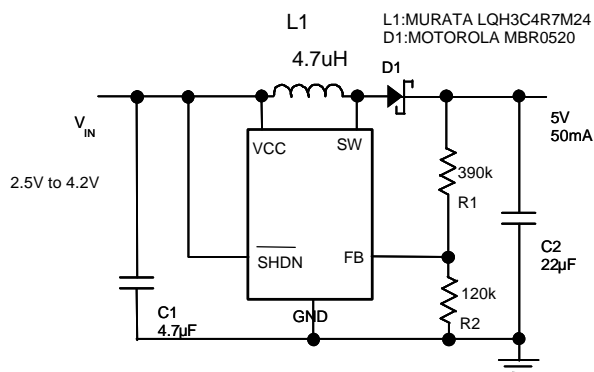

SEPIC Converter

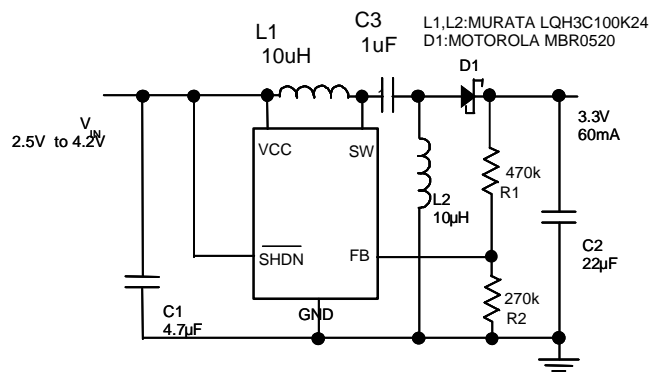

White LED Driver

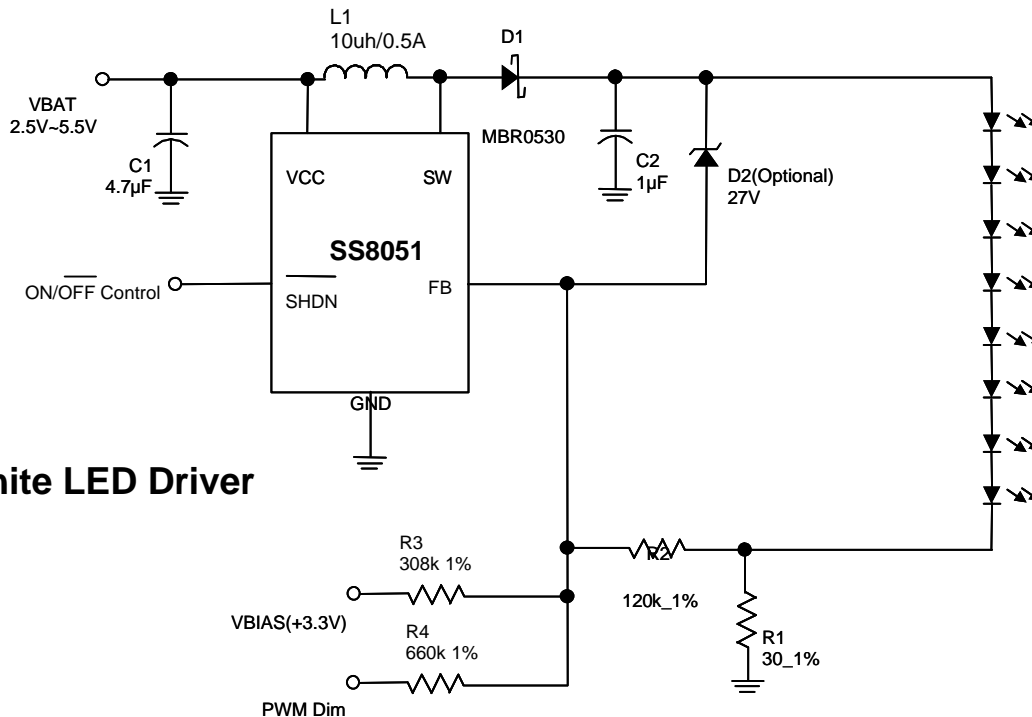

PWM Dimming Control
 VH=3.3V
 VL=0V
 Freq=160~240Hz

Dimming Ratio>50:1
Drive 2~8 White LEDs

PACKAGE DIMENSIONS

SOT-23-5 (unit: mm)

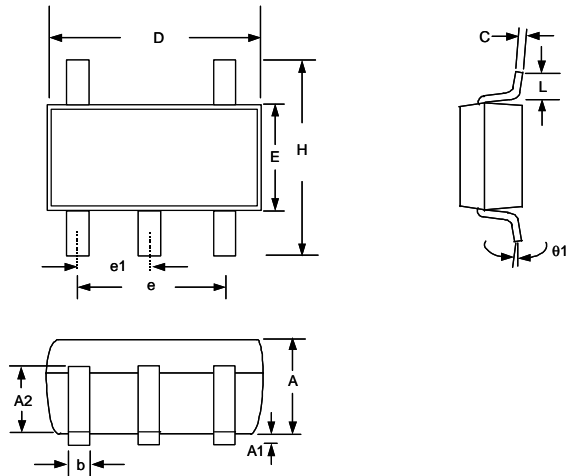

SYMBOLS	DIMENSIONS IN MILLIMETERS		
	MIN	NOM	MAX
A	1.00	1.10	1.30
A1	0.00	-----	0.10
A2	0.70	0.80	0.90
b	0.35	0.40	0.50
C	0.10	0.15	0.25
D	2.70	2.90	3.10
E	1.40	1.60	1.80
e	-----	1.90(TYP)	-----
e1	-----	0.95	-----
H	2.60	2.80	3.00
L	0.37	-----	-----
?1	1°	5°	9°

1. Package body sizes exclude mold flash protrusions or gate burrs
2. Tolerance ± 0.1000 mm (4mil) unless otherwise specified
3. Coplanarity: 0.1000mm
4. Dimension L is measured in gage plane

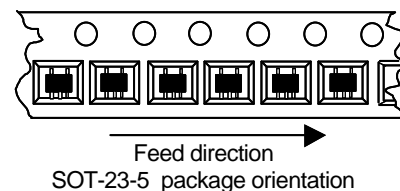

Information furnished by Silicon Standard Corporation is believed to be accurate and reliable. However, Silicon Standard Corporation makes no guarantee or warranty, express or implied, as to the reliability, accuracy, timeliness or completeness of such information and assumes no responsibility for its use, or for infringement of any patent or other intellectual property rights of third parties that may result from its use. Silicon Standard reserves the right to make changes as it deems necessary to any products described herein for any reason, including without limitation enhancement in reliability, functionality or design. No license is granted, whether expressly or by implication, in relation to the use of any products described herein or to the use of any information provided herein, under any patent or other intellectual property rights of Silicon Standard Corporation or any third parties.