

Reset Circuits with Manual Reset Input

FEATURES

- Ultra-low supply current of 1 μ A (typ.)
- Guaranteed reset valid to $V_{cc}=0.9V$
- Available in two output types:
 - Push-pull active-low (SS811)
 - Push-pull active-high (SS812)
- Power-on reset pulse width minimum 140ms
- Internally fixed threshold 2.3V, 2.6V, 2.9V, 3.1V, 4.0V, 4.4V, and 4.6V
- Tight voltage threshold tolerance: 1.5%
- Low profile package: SOT-23-5

APPLICATIONS

- Notebook Computers
- Digital Still Cameras
- PDAs
- Critical Microprocessor Monitoring

DESCRIPTION

The SS811 and SS812 are low-power microprocessor (μ P) supervisory circuits used to monitor power supplies in μ P and digital systems. They improve circuit reliability and reduce cost by eliminating external components. The SS811 and SS812 also offer a manual reset input.

These devices perform as valid singles in applications with V_{cc} ranging from 6.0V down to 0.9V. The reset signal lasts for a minimum period of 140ms whenever the V_{CC} supply voltage falls below a preset threshold. Both the SS811 and SS812 were designed with a reset comparator to help identify invalid signals lasting less than 140ms. The only difference between the SS811 and the SS812 is that one has an active-low $\overline{\text{RESET}}$ output and the other has an active-high RESET output.

A low supply current (1 μ A) makes the SS811 and SS812 ideal for portable equipment. The devices are available in a SOT-23-5 package.

TYPICAL APPLICATION CIRCUIT

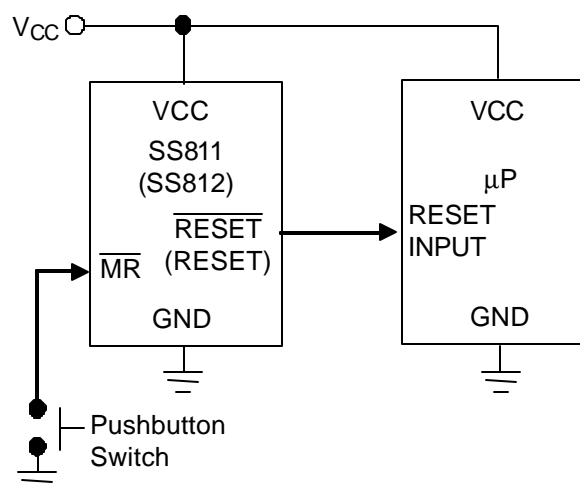

ORDERING INFORMATION

SS811-XXCXXX
 SS812-XXCXXX

- └─ Packing type
 TR: Tape and reel
- └─ Package type
 V: SOT-23-5
- └─ Reset Threshold Voltage
 - 23: 2.3V
 - 26: 2.6V
 - 29: 2.9V
 - 31: 3.1V
 - 40: 4.0V
 - 44: 4.4V
 - 46: 4.6V

PIN CONFIGURATION

SOT-23-5
 TOP VIEW
 1: GND
 2: NC
 3: RESET (RESET)
 4: MR
 5: VCC

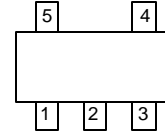

(Additional voltage versions with a unit of 0.1V within the voltage range from 1.5V to 5.5V for this product line may be available on demand with prior consultation with SSC.)

Example: SS811-31CVTR
 → 3.1V version in SOT-23-5 package, shipped in tape and reel.

SOT-23-5 Marking

Part No.	Marking
SS811-23CV	BQ23
SS811-26CV	BQ26
SS811-29CV	BQ29
SS811-31CV	BQ31
SS811-40CV	BQ40
SS811-44CV	BQ44
SS811-46CV	BQ46

Part No.	Marking
SS812-23CV	BR23
SS812-26CV	BR26
SS812-29CV	BR29
SS812-31CV	BR31
SS812-40CV	BR40
SS812-44CV	BR44
SS812-46CV	BR46

ABSOLUTE MAXIMUM RATINGS

V_{CC}	-0.3V ~ 6.5V
RESET, $\overline{\text{RESET}}$	-0.3V ~ (VCC+0.3V)
Input Current ($V_{CC}, \overline{\text{MR}}$)	20mA
Output Current (RESET or $\overline{\text{RESET}}$)	20mA
Continuous Power Dissipation ($T_A = +70^\circ\text{C}$)	320mW
Operating Junction Temperature Range	-40°C ~ 85°C
Storage Temperature Range	- 65°C ~ 150°C
Lead Temperature (Soldering) 10 sec	260°C

Note1: Any stress beyond the Absolute Maximum Ratings above may cause permanent damage to the device.

TEST CIRCUIT

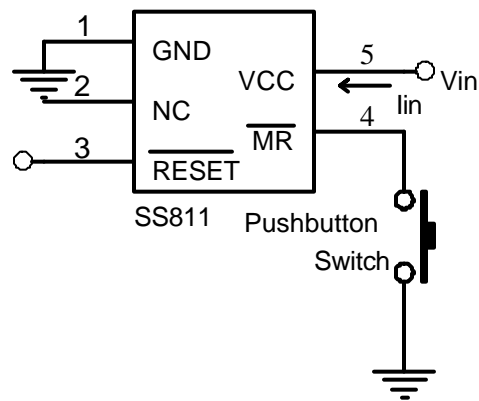

ELECTRICAL CHARACTERISTICS

(Typical values are at $T_A=25^\circ\text{C}$, unless otherwise specified)

PARAMETER	SYMBOL	TEST CONDITIONS	MIN.	TYP.	MAX.	UNIT	
Operating Voltage Range	V_{CC}		0.9		6	V	
Supply Current	I_{CC}	$V_{CC} = V_{TH} + 0.1V$		1	3	μA	
Reset Threshold	V_{TH}	SS811-23	$T_A=+25^\circ\text{C}$	2.265	2.3	2.335	V
			$T_A= -40^\circ\text{C to } +85^\circ\text{C}$	2.254		2.346	
		SS811-26	$T_A=+25^\circ\text{C}$	2.561	2.6	2.639	
			$T_A= -40^\circ\text{C to } +85^\circ\text{C}$	2.548		2.652	
		SS811-29	$T_A=+25^\circ\text{C}$	2.857	2.9	2.944	
			$T_A= -40^\circ\text{C to } +85^\circ\text{C}$	2.842		2.958	
		SS811-31	$T_A=+25^\circ\text{C}$	3.054	3.1	3.147	
			$T_A= -40^\circ\text{C to } +85^\circ\text{C}$	3.038		3.162	
		SS811-40	$T_A=+25^\circ\text{C}$	3.940	4.0	4.060	
			$T_A= -40^\circ\text{C to } +85^\circ\text{C}$	3.920		4.080	
		SS811-44	$T_A=+25^\circ\text{C}$	4.334	4.4	4.466	
			$T_A= -40^\circ\text{C to } +85^\circ\text{C}$	4.312		4.488	
		SS811-46	$T_A=+25^\circ\text{C}$	4.531	4.6	4.669	
			$T_A=-40^\circ\text{C to } +85^\circ\text{C}$	4.508		4.692	
V_{CC} to Reset Delay	T_{RD}	$V_{CC}=V_{TH}$ to $(V_{TH}-0.1V)$, $V_{TH}=3.1V$		20		μs	
Reset Active Timeout Period	T_{RP}	$V_{CC} = V_{TH(MAX)}$	$T_A=+25^\circ\text{C}$	140	230	560	mS
			$T_A= -40^\circ\text{C to } +85^\circ\text{C}$	100		1030	
$\overline{\text{MR}}$ to Reset Propagation Delay	T_{MD}	$V_{CC}=6V$		0.5		μs	
$\overline{\text{MR}}$ Input Threshold	V_{IH}		$0.7V_{CC}$			V	
	V_{IL}				$0.25V_{CC}$		
$\overline{\text{MR}}$ Pull-Up Resistance			10	20	30	$\text{K}\Omega$	
$\overline{\text{RESET}}$ Output Voltage	V_{OH}	$V_{CC}=V_{TH}+0.1V$, $I_{SOURCE}=1\text{mA}$	$0.8V_{CC}$			V	
	V_{OL}	$V_{CC}=V_{TH} - 0.1V$, $I_{SINK}=1\text{mA}$			$0.2V_{CC}$		
RESET Output Voltage	V_{OH}	$V_{CC}=V_{TH}+0.1V$, $I_{SOURCE}=1\text{mA}$	$0.8V_{CC}$			V	
	V_{OL}	$V_{CC}=V_{TH} - 0.1V$, $I_{SINK}=1\text{mA}$			$0.2V_{CC}$		

Note2: $\overline{\text{RESET}}$ output is for the SS811; RESET output is for the SS812.

Note3: Specifications for operating temperature ranges from -40°C to 85°C , are guaranteed by Statistical Quality Controls (SQC), with no production testing.

TYPICAL PERFORMANCE CHARACTERISTICS

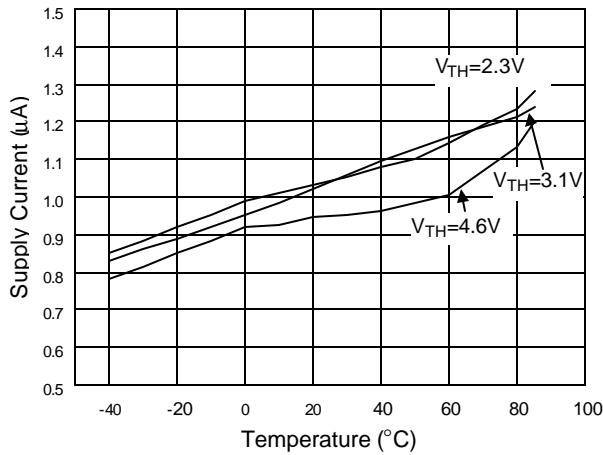

Fig 1 Supply Current vs. Temperature

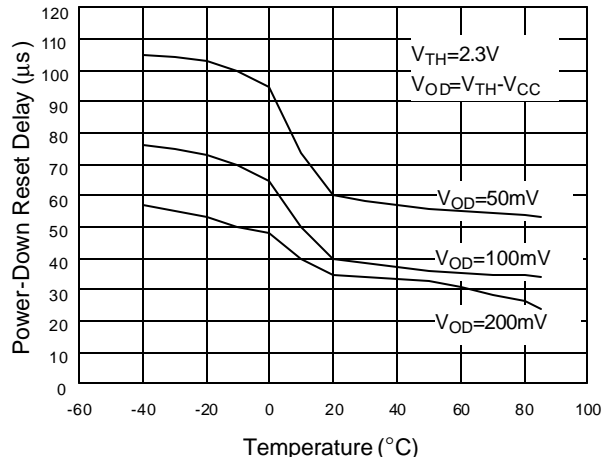

Fig 2 Power-Down Reset Delay vs. Temperature

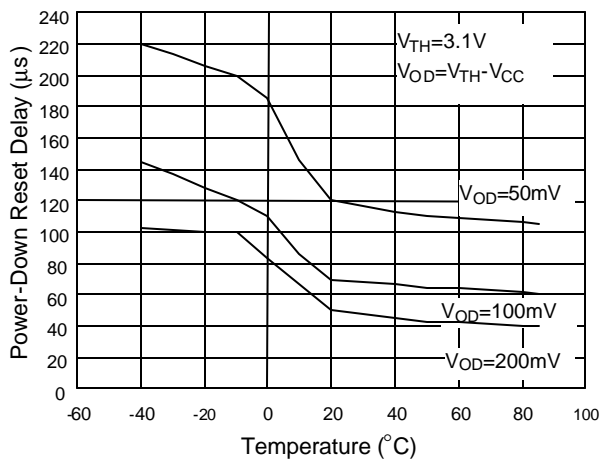

Fig 3 Power-Down Reset Delay vs. Temperature

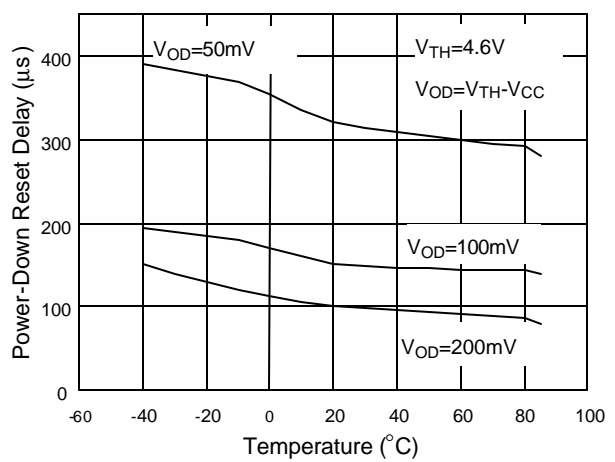

Fig 4 Power-Down Reset Delay vs. Temperature

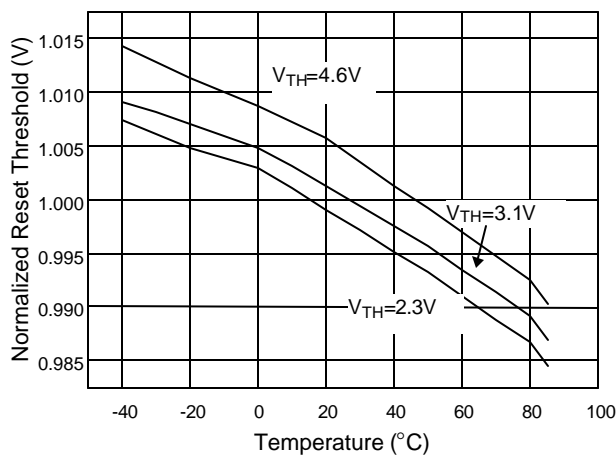

Fig 5 Normalized Reset Threshold vs. Temperature

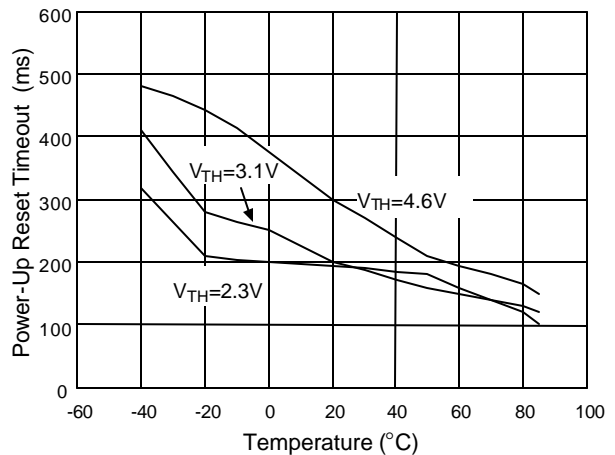
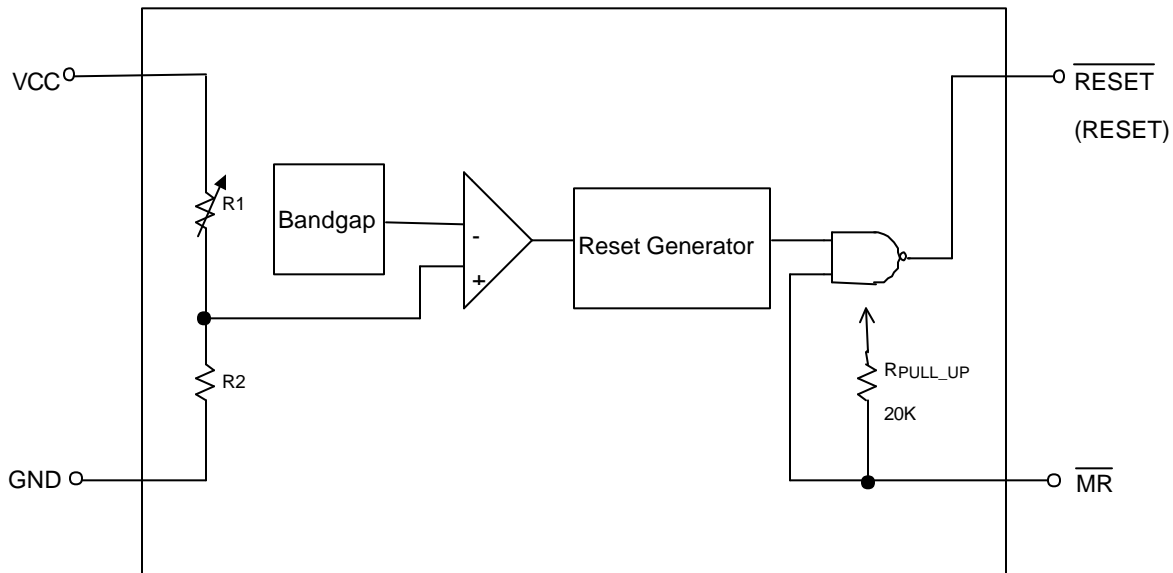

Fig 6 Power-Up Reset Timeout vs. Temperature

BLOCK DIAGRAM



PIN DESCRIPTIONS

- GND Pin : Ground.
- $\overline{\text{RESET}}$ Pin (SS811) : Active low output pin. $\overline{\text{RESET}}$ Output remains low while Vcc is below reset threshold.
- RESET Pin (SS812) : Active high output pin. RESET output remains high while Vcc is below reset threshold.
- $\overline{\text{MR}}$ Pin : Logic low manual reset input. This active-low input has an internal 20k Ω pull-up resistor. It can be driven by a TTL or CMOS, or shorted to ground with a switch. Leave open when unused.
- Vcc Pin : Supply voltage.

DETAILED DESCRIPTIONS OF TECHNICAL TERMS

RESET OUTPUT

The microprocessor will be activated at a valid reset state. These μ P supervisory circuits assert reset to prevent code execution errors during power-up, power-down, or brownout conditions.

$\overline{\text{RESET}}$ is guaranteed to be a logic low for $V_{\text{TH}} > V_{\text{CC}} > 0.9\text{V}$. Once VCC exceeds the reset threshold, an internal timer keeps $\overline{\text{RESET}}$ low for the reset timeout period; after this interval, $\overline{\text{RESET}}$

goes high.

If a brownout condition occurs (VCC drops below the reset threshold), $\overline{\text{RESET}}$ goes low. Any time VCC goes below the reset threshold, the internal timer resets to zero, and $\overline{\text{RESET}}$ goes low. The internal timer is activated after VCC returns above the reset threshold, and $\overline{\text{RESET}}$ remains low for the reset timeout period.

The manual reset input ($\overline{\text{MR}}$) can also initiate a reset. The SS812 has an active-high RESET output that is the inverse of the SS811's $\overline{\text{RESET}}$ output.

MANUAL RESET INPUT

Many microprocessor-based products require manual reset capability, allowing operators, test technicians, or external logic circuitry to initiate a reset. Logic low on \overline{MR} asserts reset. Reset will remain asserted for the Reset Active Timeout Period (t_{RP}) after \overline{MR} returns high. This input has an internal 20KΩ pull-up resistor, so it can be floating if it is not used. \overline{MR} can be driven with TTL or CMOS-logic levels, or with open-drain/collector outputs. Another alternative is to connect a normal switch from \overline{MR} to GND to create a manual reset function. Connecting a 0.1μF capacitor from \overline{MR} to ground can provide noise immunity to

prevent noise caused by long cables of \overline{MR} or noisy environment.

BENEFITS OF HIGHLY ACCURATE RESET THRESHOLD

The SS811/812 with specified voltage as $5V \pm 10\%$ or $3V \pm 10\%$ are ideal for systems using a $5V \pm 5\%$ or $3V \pm 5\%$ power supply. The reset is guaranteed to assert after the power supply falls out of regulation, but before power drops below the minimum specified operating voltage range of the system ICs. The pre-trimmed thresholds reduce the range over which an undesirable reset may occur.

APPLICATION INFORMATION

NEGATIVE-GOING VCC TRANSIENTS

In addition to issuing a reset to the microprocessor during power-up, power-down, and brownout conditions, the SS811 series are relatively resistant to short-duration negative-going VCC transient.

ENSURING A VALID RESET OUTPUT DOWN TO VCC=0

When VCC falls below 0.9V, the SS811 \overline{RESET} output no longer sinks current; it becomes an open circuit. In this case, high-impedance CMOS logic inputs connected to \overline{RESET} can drift to undetermined voltages. Therefore, the SS811/2 is perfect for most CMOS applications with VCC down to 0.9V. However in applications where \overline{RESET} must be valid down to

0V, adding a pull-down resistor to \overline{RESET} causes any leakage currents to flow to ground, holding \overline{RESET} low.

INTERFACING TO MICROPROCESSORS WITH BIDIRECTIONAL RESET PINS

Microprocessors with bidirectional reset pins may have contention with the SS811/812 reset outputs. If the SS811 \overline{RESET} output is asserted high and the microprocessor wants to pull it low, indeterminate logic levels may occur. To correct such cases, connect a resistor between the SS811 \overline{RESET} (or SS812 RESET) output and the microprocessor reset I/O. Buffer the reset output to other system components.

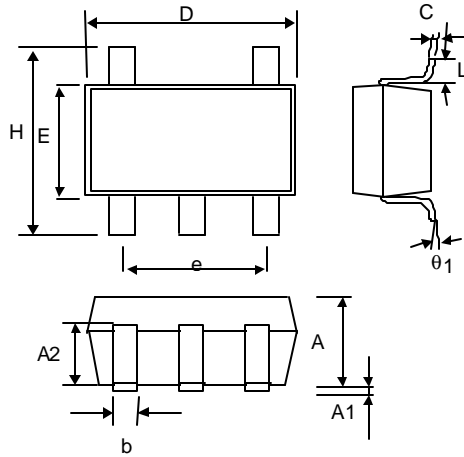
PHYSICAL DIMENSIONS
SOT-23-5 (unit: mm)

SYMBOL	MIN	MAX
A	1.00	1.30
A1	—	0.10
A2	0.70	0.90
b	0.35	0.50
C	0.10	0.25
D	2.70	3.10
E	1.40	1.80
e	1.90 (TYP)	
H	2.60	3.00
L	0.37	—
θ_1	1°	9°

Information furnished by Silicon Standard Corporation is believed to be accurate and reliable. However, Silicon Standard Corporation makes no guarantee or warranty, express or implied, as to the reliability, accuracy, timeliness or completeness of such information and assumes no responsibility for its use, or for infringement of any patent or other intellectual property rights of third parties that may result from its use. Silicon Standard reserves the right to make changes as it deems necessary to any products described herein for any reason, including without limitation enhancement in reliability, functionality or design. No license is granted, whether expressly or by implication, in relation to the use of any products described herein or to the use of any information provided herein, under any patent or other intellectual property rights of Silicon Standard Corporation or any third parties.