

25A Dual Schottky Rectifiers

PRODUCT SUMMARY

Voltage ratings available from 35 to 60 Volts

FEATURES

- Plastic packages have Underwriters Laboratory Flammability Classification 94V-0
- Dual rectifier construction, positive center tap
- Metal-silicon junction, majority carrier conduction
- Low power loss, high efficiency
- Guard-ring for overvoltage protection
- For use in low voltage, high frequency inverters, free wheeling, and polarity protection applications

MECHANICAL DATA

- High temperature soldering guaranteed:
250°C for 10 seconds, 0.25" (6.35mm) from case
- Case: JEDEC TO-220AB (MBR...) or ITO-220AB (MBRB...) molded plastic body - for dimensions, see page 3
- Terminals: Matte-Sn plated leads, solderable per MIL-STD-750, method 2026
- Polarity: As marked
- Mounting Position: Any
- Mounting Torque: 10 in-lbs maximum
- Weight: 0.08 ounce, 2.24 grams

 Pb-free; RoHS-compliant

MAXIMUM RATINGS AND ELECTRICAL CHARACTERISTICS

- Rating at 25°C ambient temperature unless otherwise specified.
- Single phase, half wave, 60 Hz, resistive or inductive load.
- For capacitive load, derate current by 20%

Parameter	Symbol	MBR2535CT	MBR2545CT	MBR2550CT	MBR2560CT	Units
		MBRB2535CT	MBRB2545CT	MBRB2550CT	MBRB2560CT	
Maximum repetitive peak reverse voltage	V_{RRM}	35	45	50	60	Volts
Working peak reverse voltage	V_{RWM}	35	45	50	60	Volts
Maximum DC blocking voltage	V_{DC}	35	45	50	60	Volts
Maximum average forward rectified current at $T_C=130^\circ\text{C}$	Total device Per leg I_{FAV}	25 12.5				Amps
Peak repetitive forward current per leg at (rated V_R , sq. wave 20kHz) at $T_C=130^\circ\text{C}$	I_{FRM}	30				Amps
Peak forward surge current 8.3ms single half sine-wave superimposed on rated load (JEDEC Method) per leg	I_{FSM}	150				Amps
Peak repetitive reverse surge current per leg at $t_p = 2.0\mu\text{s}$, 1KHz	I_{RRM}	1.0		0.5		Amps
Voltage rate of change (rated V_R)	dv/dt	10,000				V/us
Maximum instantaneous forward voltage per leg (Note 1) at $I_F=12.5\text{A}$, $T_C=25^\circ\text{C}$ at $I_F=12.5\text{A}$, $T_C=125^\circ\text{C}$ at $I_F=25\text{A}$, $T_C=25^\circ\text{C}$ at $I_F=25\text{A}$, $T_C=125^\circ\text{C}$	V_F	-	-	0.75	0.65	Volt
Maximum reverse current at rated DC blocking voltage per leg (Note 1) $T_C=25^\circ\text{C}$ $T_C=125^\circ\text{C}$	I_R	0.2	40	1.0	50	mA
Thermal resistance from junction to case per leg	$R_{\theta JC}$	1.5				$^\circ\text{C/W}$
Operating junction temperature range	T_J	-55 to +150				$^\circ\text{C}$
Storage temperature range	T_{STG}	-55 to +150				$^\circ\text{C}$

Notes: 1. Pulse test: 300us pulse width, 1% duty cycle

RATINGS AND CHARACTERISTIC CURVES

($T_A = 25^\circ\text{C}$ unless otherwise noted)

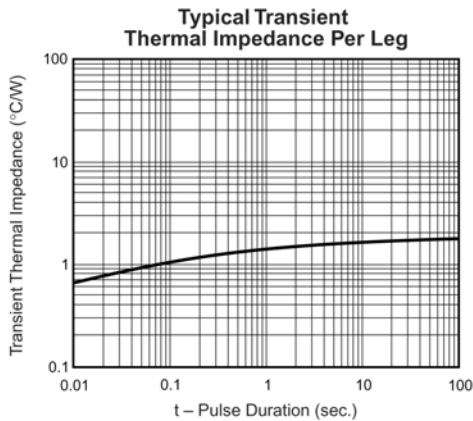
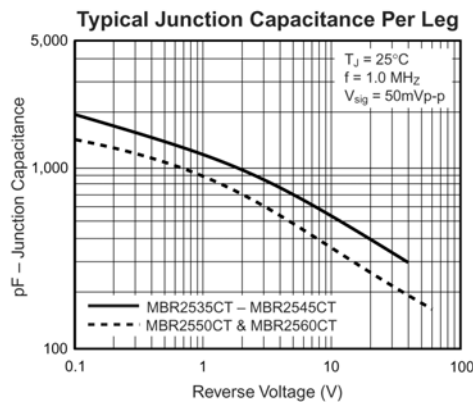
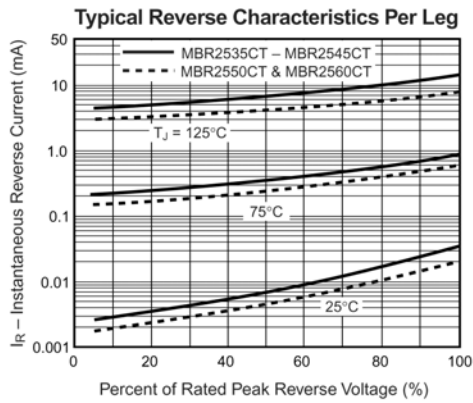
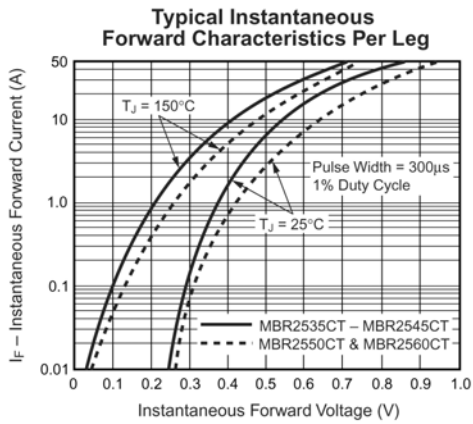
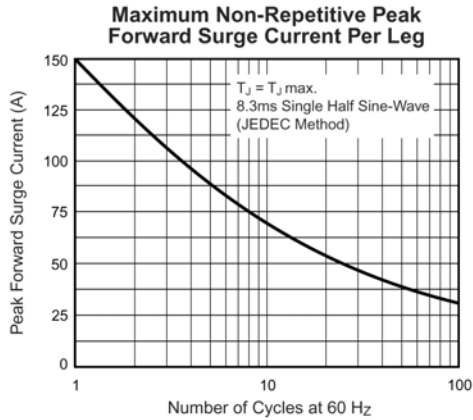
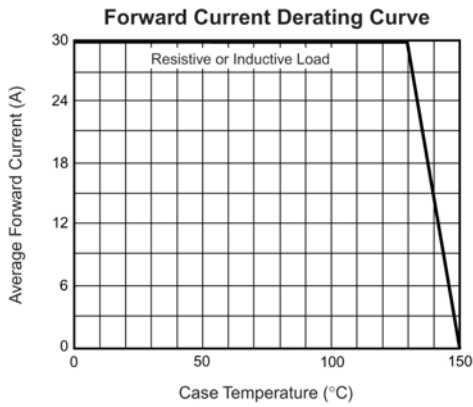

PHYSICAL DIMENSIONS

ITO-220AB

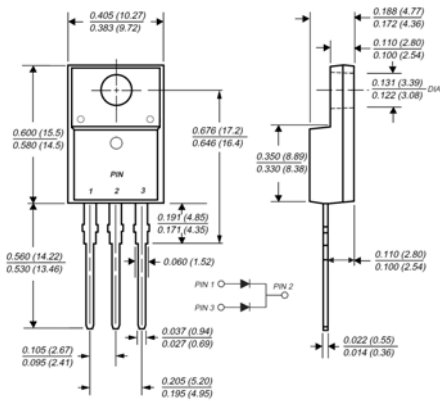

TO-220AB

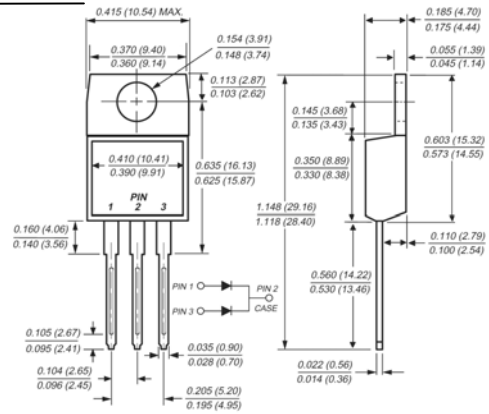

Dimensions in inches and (millimeters)

Information furnished by Silicon Standard Corporation is believed to be accurate and reliable. However, Silicon Standard Corporation makes no guarantee or warranty, expressed or implied, as to the reliability, accuracy, timeliness or completeness of such information and assumes no responsibility for its use, or for infringement of any patent or other intellectual property rights of third parties that may result from its use. Silicon Standard reserves the right to make changes as it deems necessary to any products described herein for any reason, including without limitation enhancement in reliability, functionality or design. No license is granted, whether expressly or by implication, in relation to the use of any products described herein or to the use of any information provided herein, under any patent or other intellectual property rights of Silicon Standard Corporation or any third parties.