

Dual USB High-Side Power Switch

■ FEATURES

- 110m Ω (5V Input) High-Side MOSFET Switch.
- 500mA Continuous Load Current per Channel.
- 110 μ A Typical On-State Supply Current.
- 1 μ A Typical Off-State Supply Current.
- Current-Limit / Short Circuit Protection.
- Thermal Shutdown Protection under Overcurrent Condition.
- Undervoltage Lockout Ensures that Switch is off at Start Up.
- Output can be Forced Higher than Input (Off-State).
- Open-Drain Fault Flag.
- Slow Turn ON and Fast Turn OFF.
- Enable Active-High or Active-Low.

■ APPLICATIONS

- USB Power Management.
- Hot Plug-In Power Supplies.
- Battery-Charger Circuit.

■ DESCRIPTION

The SS6526 is a dual high-side power switch for self-powered and bus-powered Universal Serial Bus (USB) applications. Both high-side switches are MOSFET with 110m Ω $R_{DS(ON)}$, which meets USB voltage drop requirements for maximum transmission wire length.

Multi-purpose open-drain fault flag output indicates over-current limiting, thermal shutdown, or undervoltage lockout for each channel. Output current is typically limited to 1A, and the thermal shutdown functions of the power switches independently control their channel under overcurrent condition.

Guaranteed minimum output rise time limits inrush current during hot plug-in as well as minimizing EMI and prevents the voltage at upstream port from dropping excessively.



TYPICAL APPLICATION CIRCUIT

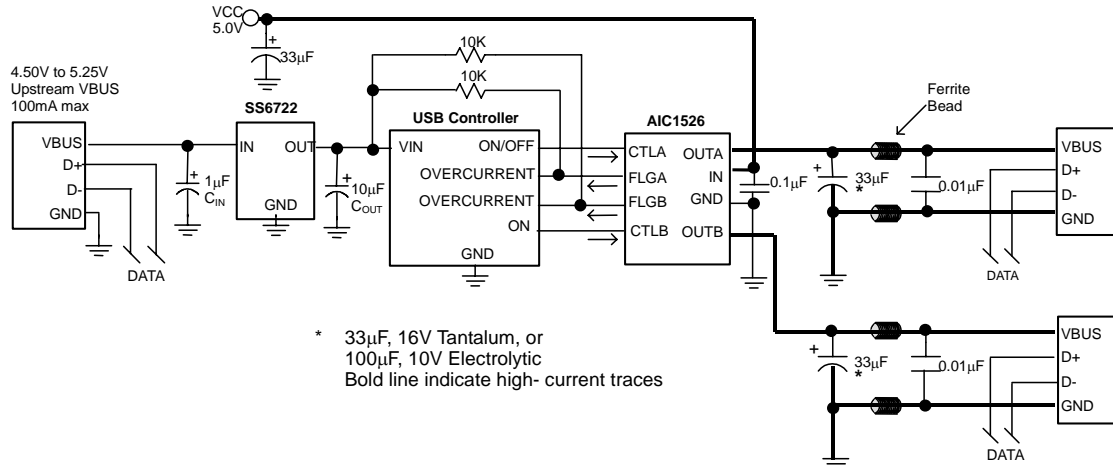

Two-Port Self-Powered Hub

ORDERING INFORMATION

SS6526 - XXXXX

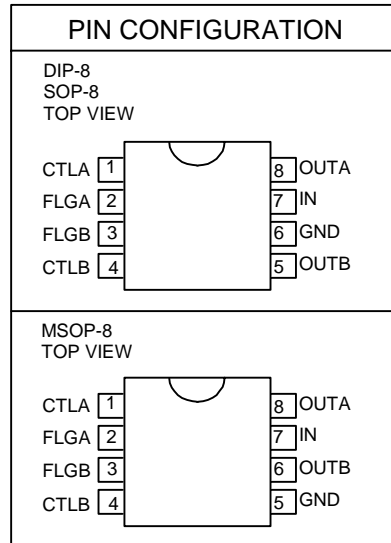
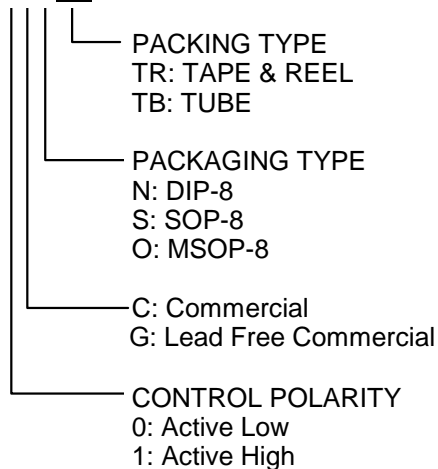

Example: SS6526-0CSTR

- Active Low Version, in SOP-8 Package & Taping & Reel Packing Type
(CN is not available in TR packing)

SS6526-1PSTR

- Active High Version, in Lead Free SOP-8 Package & Taping & Reel Packing Type

■ ABSOLUTE MAXIMUM RATINGS

Supply Voltage (V_{IN})	7.0V
Fault Flag Voltage (V_{FLG})	7.0V
Fault Flag Current (I_{FLG})	50mA
Control Input (V_{CTL})	-0.3V ~7V
Operating Temperature Range	-40°C~85°C
Junction Temperature	125°C
Storage Temperature Range	-65°C ~ 150°C
Lead Temperature (Soldering, 10sec)	260°C
Thermal Resistance, θ_{JA} (Junction to Ambient)	DIP-8.....	100°C/W
(Assume no Ambient Airflow, no Heatsink)	SOP-8.....	160°C/W
	MSOP-8.....	180°C/W
Thermal Resistance, θ_{JC} (Junction to Case)	DIP-8.....	60°C/W
	SOP-8.....	40°C/W
	MSOP-8.....	75°C/W

Absolute Maximum Ratings are those values beyond which the life of a device may be impaired.

■ TEST CIRCUIT

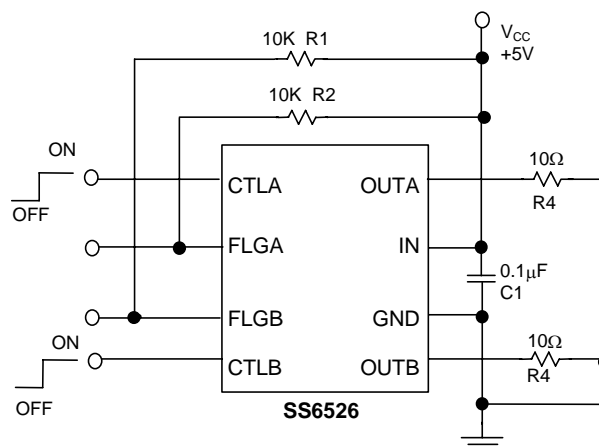

■ ELECTRICAL CHARACTERISTICS

($V_{IN}=5V$, $T_A=25^{\circ}C$, unless otherwise specified.) (Note 1)

PARAMETERS	CONDITIONS	MIN.	TYP.	MAX.	UNIT
Supply Current	$V_{CTL} = \text{Logic "0"}$, OUT=Open		0.75	5	μA
	$V_{CTL} = \text{Logic "1"}$, OUT=Open		110	160	
Control Input Voltage	$V_{CTL} = \text{Logic "0"}$			0.8	V
	$V_{CTL} = \text{Logic "1"}$	2.4			
Control Input Current	$V_{CTL} = \text{Logic "0"}$		0.01	1	μA
	$V_{CTL} = \text{Logic "1"}$		0.01	1	
Control Input Capacitance			1		pF
Output MOSFET Resistance			110	150	m Ω
Output Turn-On Rise Delay	$R_L = 10\Omega$ each Output		100		μS
Output Turn-On Rise Time	$R_L = 10\Omega$ each Output		1000	2500	μS
Output Turn-Off Delay	$R_L = 10\Omega$ each Output		0.8	20	μS
Output Turn-Off Fall Time	$R_L = 10\Omega$ each Output		0.7	20	μS
Output Leakage Current				10	μA
Current Limit Threshold		0.6	1.0	1.25	A
Over Temperature Shutdown Threshold	T_J Increasing		135		$^{\circ}C$
	T_J Decreasing		125		
Error Flag Output Resistance	$V_{IN} = 5V$, $I_L = 10\text{ mA}$		10	25	Ω
	$V_{IN} = 3.3V$, $I_L = 10\text{ mA}$		15	40	
Error Flag Off Current	$V_{FLG} = 5V$		0.01	1	μA
UVLO Threshold	V_{IN} Increasing		2.6		V
	V_{IN} Decreasing		2.4		

Note 1: Specifications are production tested at $T_A=25^{\circ}C$. Specifications over the $-40^{\circ}C$ to $85^{\circ}C$ operating temperature range are assured by design, characterization and correlation with Statistical Quality Controls (SQC).

TYPICAL PERFORMANCE CHARACTERISTICS

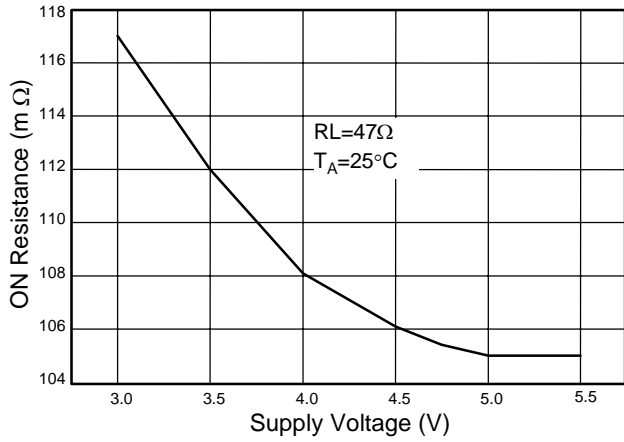

Fig. 1 ON Resistance vs. Supply Voltage

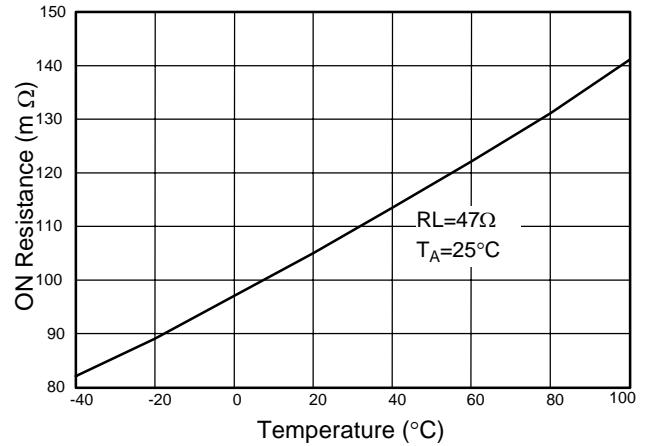

Fig. 2 Output On Resistance vs. Temperature

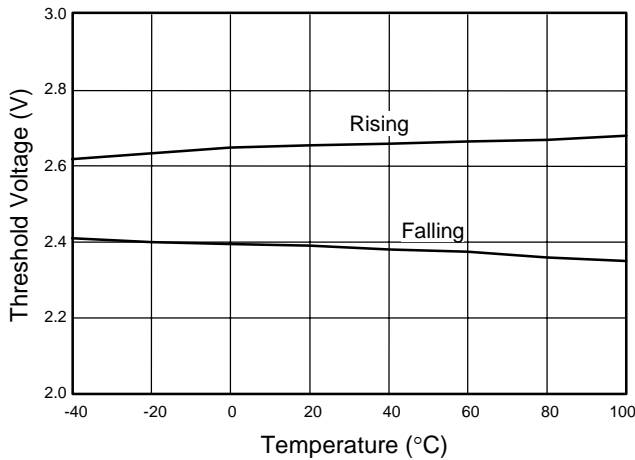

Fig. 3 UVLO Threshold Voltage vs. Temperature

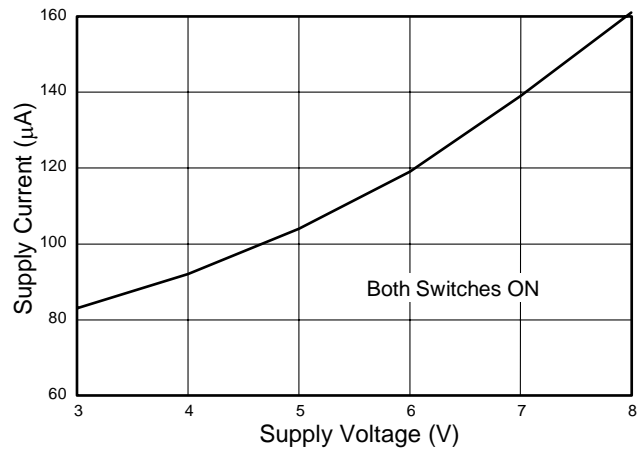

Fig. 4 ON-State Supply Current vs. Supply Voltage

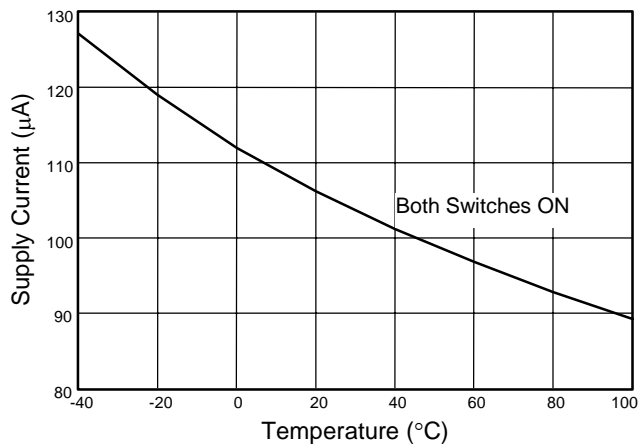

Fig. 5 ON State Current vs. Temperature

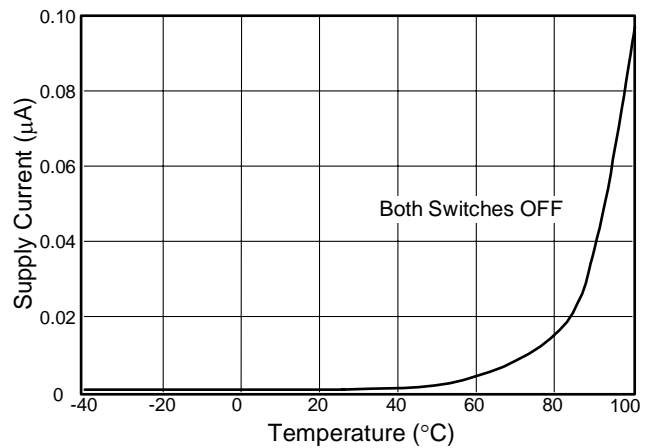

Fig. 6 OFF-State Current vs. Temperature

TYPICAL PERFORMANCE CHARACTERISTICS (Continued)

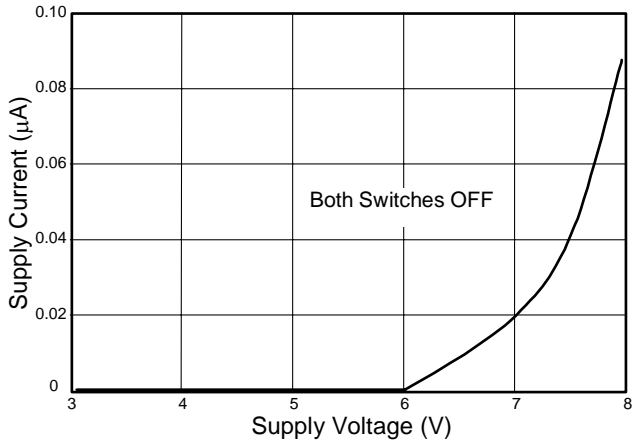

Fig. 7 OFF-State Current vs. Supply Voltage

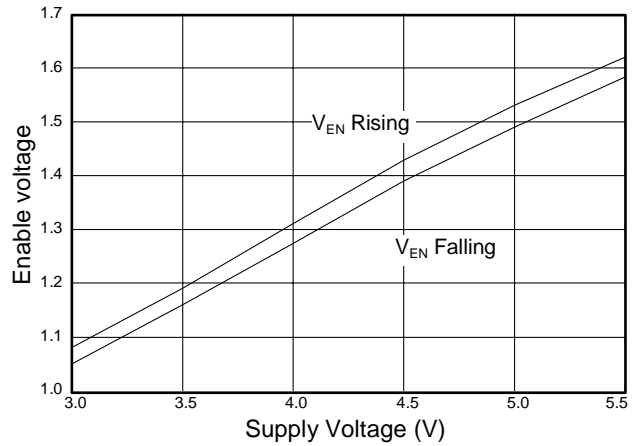

Fig. 8 Control Threshold vs. Supply Voltage

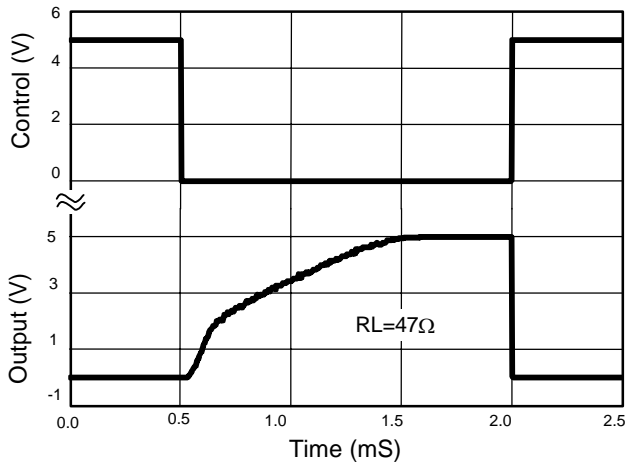

Fig. 9 Turn-On, Turn-Off Characteristics

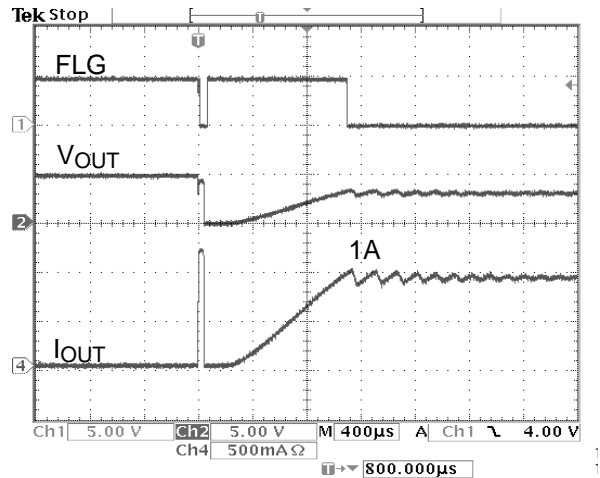
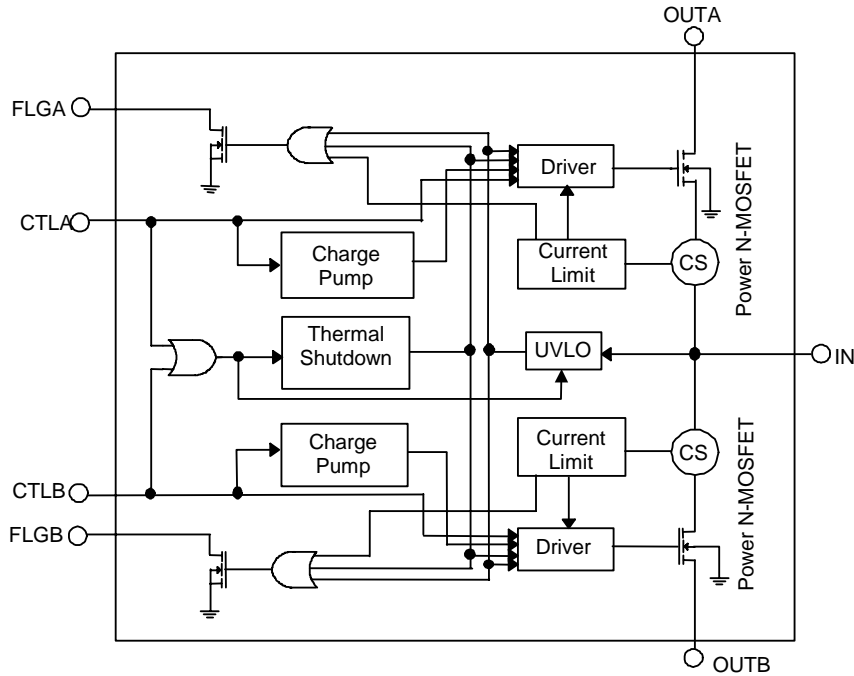

Fig. 10 Current Limit Response

■ BLOCK DIAGRAM



■ PIN DESCRIPTIONS

- | | |
|--|---|
| <p>PIN 1: CTLA - Controls the turn-on/turn-off of channel A MOSFET with TTL as a control input. Active high for SS6526-1 and active low for SS6526-0.</p> | <p>PIN 4: CTLB - Controls the turn-on/turn-off of channel B MOSFET with TTL as a control input. Active High for SS6526-1 and active low for SS6526-0.</p> |
| <p>PIN 2: FLGA - An active-low and open-drained fault flag output for channel A. FLGA is an indicator for current limit when CTLA is active. In normal mode operation (CTLA or/and CTLB is active), it also can indicate thermal shutdown or undervoltage.</p> | <p>PIN 5: OUTB - Channel B MOSFET switch output.</p> |
| <p>PIN 3: FLGB - An active-low and open-drained fault flag output for channel B. FLGB is an indicator for current limit when CTLB is active. In normal mode operation (CTLB or/and CLTA is active), it also can indicate thermal shutdown or undervoltage.</p> | <p>PIN 6: GND - Chip power ground.</p> <p>PIN 7: IN - Power supply input.</p> <p>PIN 8: OUTA - Channel A MOSFET switch output.</p> |

■ APPLICATION INFORMATION

● Error Flag

An error Flag is an open-drained output of an N-channel MOSFET. FLG output is pulled low to signal the following fault conditions: input undervoltage, output current limit, and thermal shutdown.

● Current Limit

The current limit threshold is preset internally. It protects the output MOSFET switches from damage resulting from undesirable short circuit conditions or excess inrush current, which is often encountered during hot plug-in. The low limit of the current limit threshold of the SS6526 allows a minimum current of 0.6A through the MOSFET switches. The error flag signals when any current limit conditions occur.

● Thermal Shutdown

When temperature of SS6526 exceeds 135°C for any reasons, the thermal shutdown function turns both MOSFET switches off and signals the error flag. A hysteresis of 10°C prevents the MOSFETs from turning back on until the chip temperature drops below 125°C. However, if thermal shutdown is triggered by chip temperature rise resulting from overcurrent fault condition of either one of the MOSFET switches, the thermal shutdown function will only turn off the switch that is in overcurrent condition and the other switch can still remain its normal operation. In other words, the thermal shutdown function of the two switches is independent of each other in the case of overcurrent fault.

● Supply Filtering

A 0.1 μ F to 1 μ F bypass capacitor from IN to GND, located near the device, is strongly recommended to control supply transients. Without a bypass capacitor, an output short may cause sufficient ringing on the input (from supply lead inductance) to damage internal control circuitry.

● Transient Requirements

USB supports dynamic attachment (hot plug-in) of peripherals. A current surge is caused by the input capacitance of downstream device. Ferrite beads are recommended in series with all power and ground connector pins. Ferrite beads reduce EMI and limit the inrush current during hot-attachment by filtering high-frequency signals.

● Short Circuit Transient

Bulk capacitance provides the short-term transient current needed during a hot-attachment event. A 33 μ F/16V tantalum or a 100 μ F/10V electrolytic capacitor mounted close to downstream connector each port should provide transient drop protection.

● Printed Circuit Layout

The power circuitry of USB printed circuit boards requires a customized layout to maximize thermal dissipation and to minimize voltage drop and EMI.

APPLICATION CIRCUIT

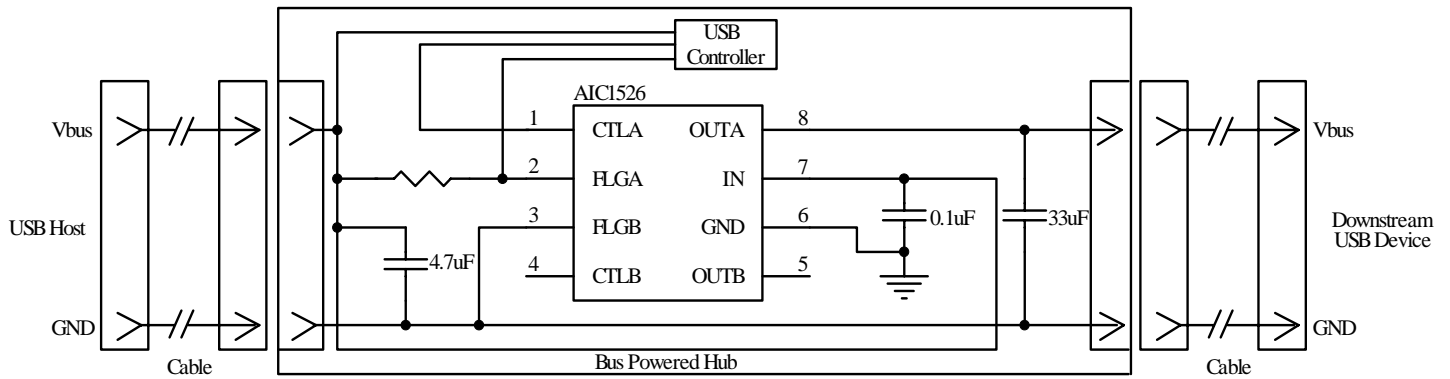

Fig. 11 Soft Start (Single Channel)

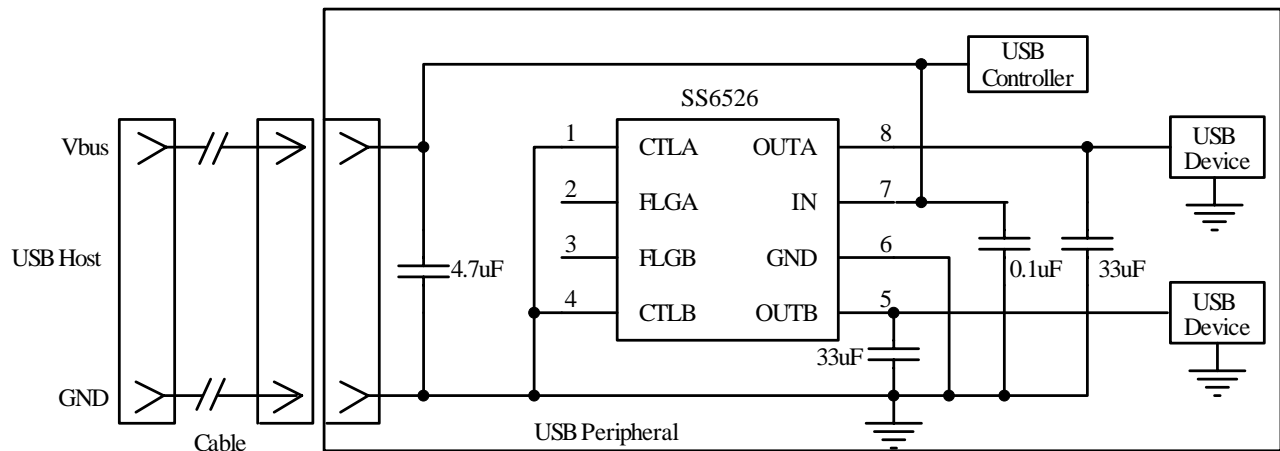
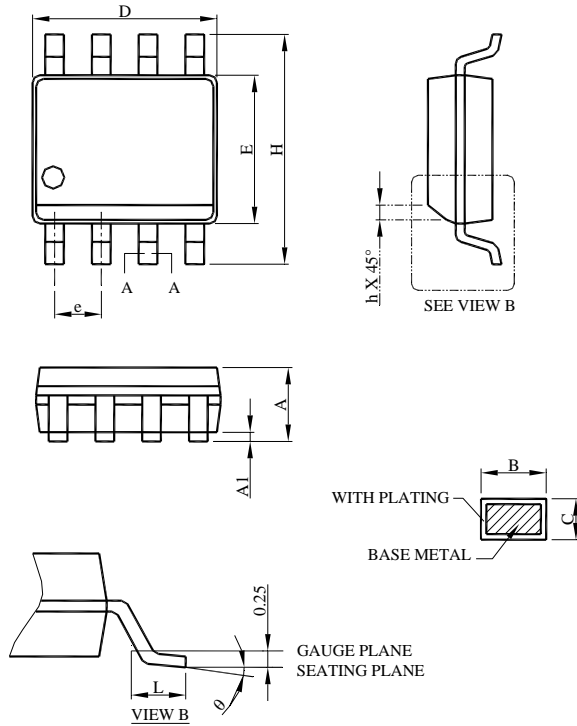

Fig. 12 Inrush Current-Limit Application

■ PHYSICAL DIMENSIONS (unit: mm)

- SOP-8



SYMBOL	SOP-8	
	MILLIMETERS	
	MIN.	MAX.
A	1.35	1.75
A1	0.10	0.25
B	0.33	0.51
C	0.19	0.25
D	4.80	5.00
E	3.80	4.00
e	1.27 BSC	
H	5.80	6.20
h	0.25	0.50
L	0.40	1.27
θ	0°	8°

Note:

1. Refer to JEDEC MS-012AA.
2. Dimension "D" does not include mold flash, protrusions or gate burrs. Mold flash, protrusion or gate burrs shall not exceed 6 mil per side.
3. Dimension "E" does not include inter-lead flash or protrusions. Inter-lead flash or protrusion shall not exceed 10 mil per side.
4. Controlling dimension is millimeter, converted inch dimensions are not necessarily exact.

● **DIP-8**

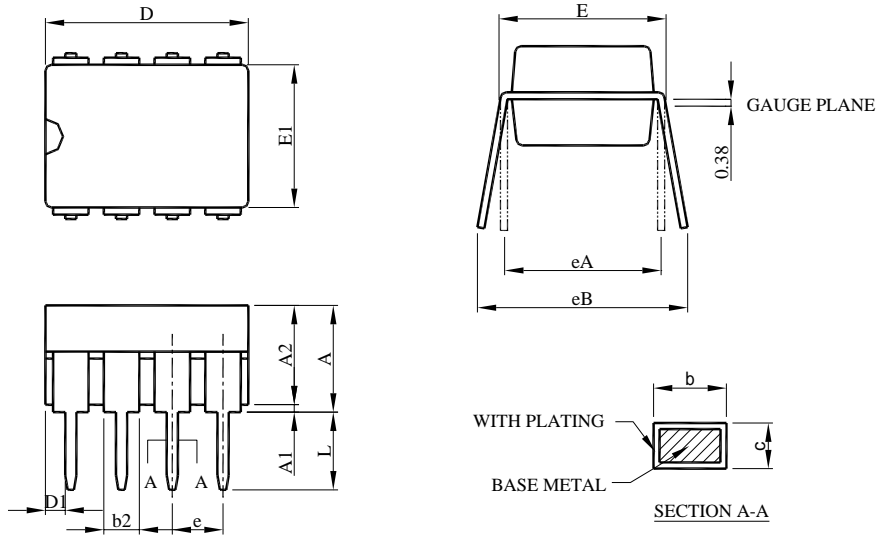

SYMBOL	DIP-8	
	MILLIMETERS	
	MIN.	MAX.
A		5.33
A1	0.38	
A2	2.92	4.95
b	0.36	0.56
b2	1.14	1.78
c	0.20	0.35
D	9.01	10.16
D1	0.13	
E	7.62	8.26
E1	6.10	7.11
e	2.54 BSC	
eA	7.62 BSC	
eB		10.92
L	2.92	3.81

Note:

1. Refer to JEDEC MS-001BA.
2. Dimension D, D1 and E1 do not include mold flash or protrusions. Mold flash or protrusion shall not exceed 10 mil.
3. Controlling dimension is millimeter, converted inch dimensions are not necessarily exact.

● **MSOP-8**

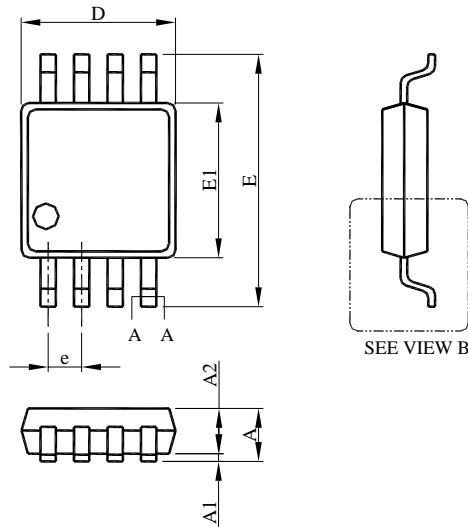

SYMBOL	MSOP-8	
	MILLIMETERS	
	MIN.	MAX.
A		1.10
A1	0.05	0.15
A2	0.75	0.95
b	0.25	0.40
c	0.13	0.23
D	2.90	3.10
E	4.90 BSC	
E1	2.90	3.10
e	0.65 BSC	
L	0.40	0.70
θ	0°	6°

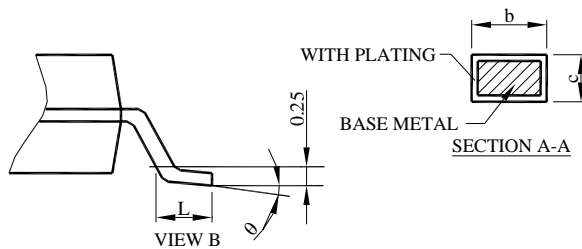

Note:

1. Refer to JEDEC MO-187AA.
2. Dimension "D" does not include mold flash, protrusions or gate burrs. Mold flash, protrusion or gate burrs shall not exceed 6 mil per side.
3. Dimension "E" does not include inter-lead flash or protrusions. Inter-lead flash and protrusions shall not exceed 10 mil per side.
4. Controlling dimension is millimeter, converted inch dimensions are not necessarily exact.

Information furnished by Silicon Standard Corporation is believed to be accurate and reliable. However, Silicon Standard Corporation makes no guarantee or warranty, expressed or implied, as to the reliability, accuracy, timeliness or completeness of such information and assumes no responsibility for its use, or for infringement of any patent or other intellectual property rights of third parties that may result from its use. Silicon Standard reserves the right to make changes as it deems necessary to any products described herein for any reason, including without limitation enhancement in reliability, functionality or design. No license is granted, whether expressly or by implication, in relation to the use of any products described herein or to the use of any information provided herein, under any patent or other intellectual property rights of Silicon Standard Corporation or any third parties.