

External NMOS Step-Down PWM Controller

FEATURES

- N-Channel MOSFET Drive
- Operating input voltage from 4.5V to 24V
- Wide output Range : 0.8V to 20V
- Reference: $\pm 1.5\%$ 0.8V Reference
- Low dropout operation : 95% duty cycle
- Fixed constant frequency - 500kHz
- Low standby current, I_Q typically 720 μ A
- Logic-control micropower shutdown
- Output overvoltage protection
- Internal diode for bootstrapped gate drive
- Current-mode operation for excellent line and load transient response
- Available in 8-lead SO or MSOP packages

APPLICATIONS

- LCD Monitor
- Palmtop Computers, PDAs
- Wireless Modems
- On-Card Switching Regulators
- DC Power Distribution Systems

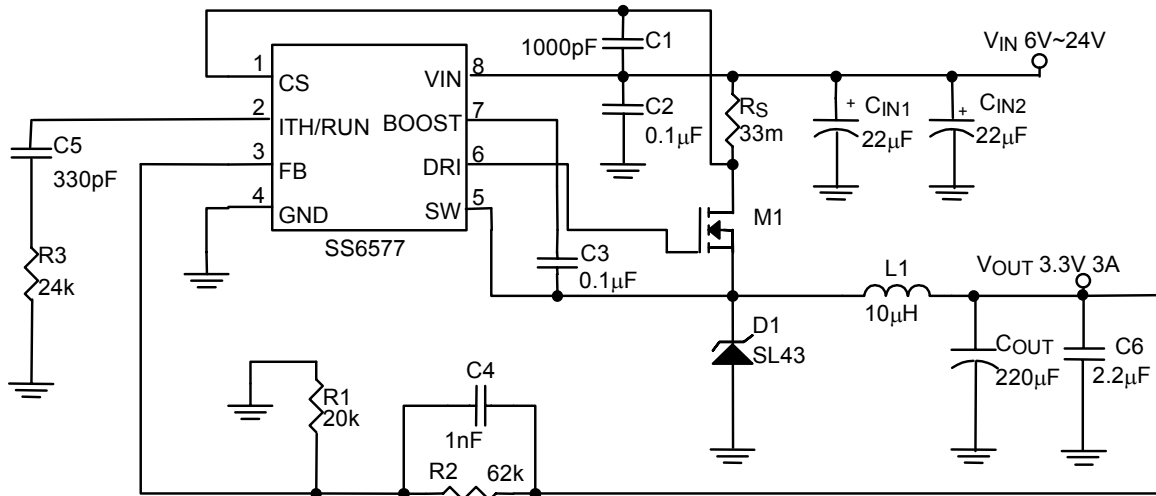
DESCRIPTION

The SS6577 is a current-mode switching regulator controller that drives an external N-channel power MOSFET using a fixed frequency architecture. It uses an external divider to adjust the output voltage from 0.8V to 20V with excellent line and load regulation. A maximum high duty-cycle limit of 95% provides low dropout operation which extends operating time in battery-operated systems.

A constant switching frequency of 500KHz is used thus allowing smaller sized filter components. The operating current level is user-programmable via an external current sense resistor. It also provides output overvoltage protection under fault conditions.

A multifunction pin (ITH/RUN) allows external compensation for optimum load step response plus shutdown. Soft start can also be implemented with this pin to properly sequence supplies. Packages available are SOP-8 and MSOP-8 for SMD.

TYPICAL APPLICATION CIRCUIT



- CIN1, CIN2: HER-MEI 22μF/35V Electrolytic capacitors
- M1: N-MOSFET SSM6680M
- D1: GS SL43
- L1: TDK SLF12555T-100M3R4
- COUT: HER-MEI 220μF /16V Electrolytic capacitor
- C6: TAIYO YUDEN LMK212BJ225KG-T Ceramic capacitor

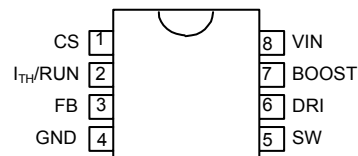
ORDERING INFORMATION

SS6577C(X)XXX

- Packing type
TB: Tube
TR: Tape and reel
- Package outline
S: SO-8
O: MSOP-8
- G: Pb-free lead finish

PIN CONFIGURATION

TOP VIEW



Example: SS6577COTR
→ in MSOP package shipped in tape and reel

SS6577CGOTR
→ in MSOP package with Pb-free lead
finish shipped in tape and reel

ABSOLUTE MAXIMUM RATINGS (Note 1)

Supply Voltage (VIN)	25V
Drive Supply Voltage (BOOST)	32V
Switch Voltage (SW)	25V
Differential Boost Voltage (BOOST to SW)	8V
I _{TH} /RUN,V _{FB} Voltages	7V
Peak Drive Output Current < 10μS (DRI)	2A
Operating Temperature Range	-40°C ~ 85°C
Thermal Resistance (θ _{JA}) (Assuming no ambient airflow, no heatsink)	
SOP8	160°C/W
MSOP8	180°C/W
Storage Temperature Range	-65°C ~ 150°C
Lead Temperature (Soldering, 10sec)	300°C

TEST CIRCUIT

Refer to Typical Application Circuit.

ELECTRICAL CHARACTERISTICS (TA=25°C, VIN=15V, unless otherwise noted.)

PARAMETER	TEST CONDITIONS	MIN.	TYP.	MAX.	UNIT
Input Voltage		4.5		24	V
Input Supply Current	Normal Mode (Note 2)		720	900	μA
	Shutdown Mode, V _{I_{TH}/RUN} =0V		16	20	μA
Feedback Voltage		0.788	0.8	0.812	V
ΔOutput Overvoltage Lockout	V _{FB} connect to V _{out} , ΔV _{OVL} =V _{OVL} -V _{FB}	20	55	90	mV
Reference Voltage Line Regulation	V _{IN} = 4.5V to 20 V		0.002	0.015	%/V
Output Voltage Load Regulation	I _{TH} Sinking 5μA		0.7	1.1	%
	I _{TH} Sourcing 5μA		-0.4	-0.8	
Run Threshold		0.6	0.8	0.9	V
Maximum Current Sense Threshold	V _{FB} =0.72V	125	150	175	mV
Oscillator Frequency		450	500	550	kHz

ELECTRICAL CHARACTERISTICS (Continued)

PARAMETER	TEST CONDITIONS	MIN.	TYP.	MAX.	UNIT
DRI Rise Time	$C_{LOAD} = 3000pF$		50	75	ns
DRI Fall Time	$C_{LOAD} = 3000pF$		50	75	ns
BOOST Voltage	$V_{IN}=8V, I_{BOOST}=5mA, SW=0V$	4.9	5.3	5.7	V
Maximum Duty Cycle		90	94		%
Soft Start Time		5	7.5		ms
Run Current Source	$V_{ITH/RUN}=0V, V_{FB}=0V$	1.0	2.3	4.0	μA
Run Pullup Current	$V_{ITH/RUN}=1V$	100	190	250	μA

Note 1: Absolute Maximum Ratings are those values beyond which the life of a device may be impaired.

Note 2: Dynamic supply current is higher due to the gate charge being delivered at the switching frequency.

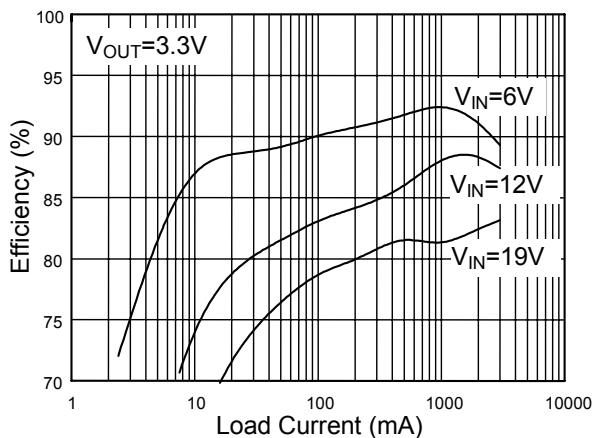
TYPICAL PERFORMANCE CHARACTERISTICS


Fig. 1 Efficiency vs Load Current ($V_{OUT}=3.3V$)

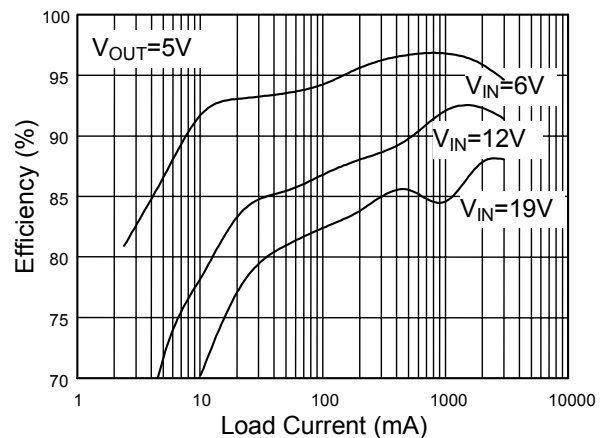


Fig. 2 Efficiency vs Load Current ($V_{OUT}=5.0V$)

TYPICAL PERFORMANCE CHARACTERISTICS (Continued)

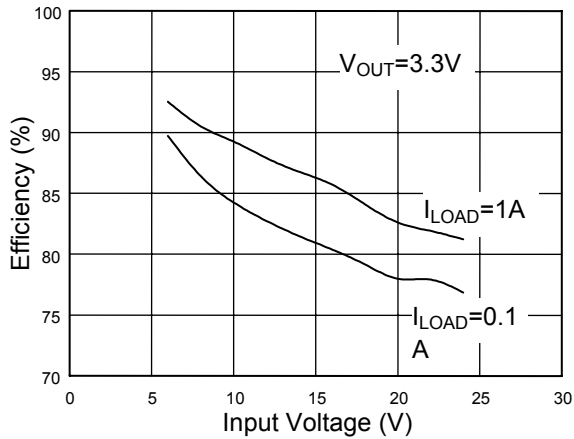


Fig. 3 Efficiency vs Input Voltage

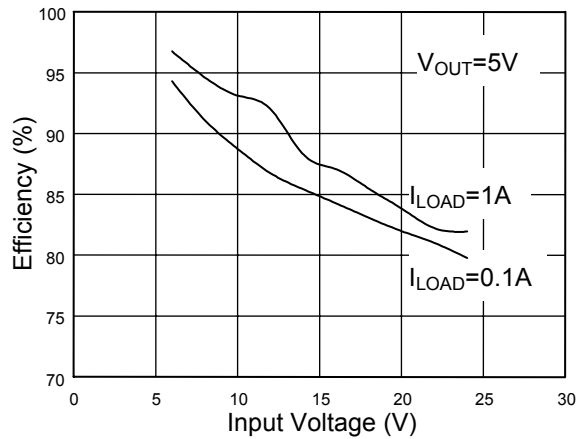


Fig. 4 Efficiency vs Input Voltage

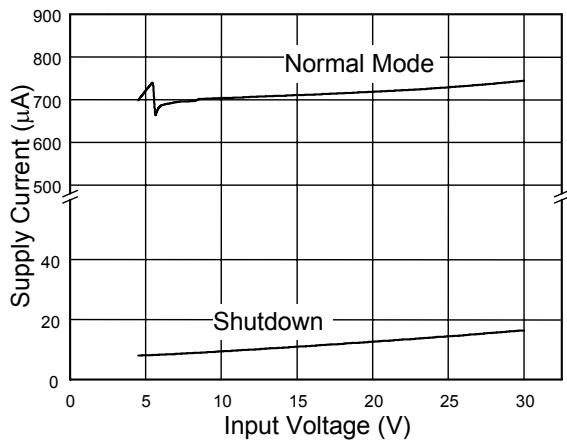


Fig. 5 Supply Current vs Input Voltage

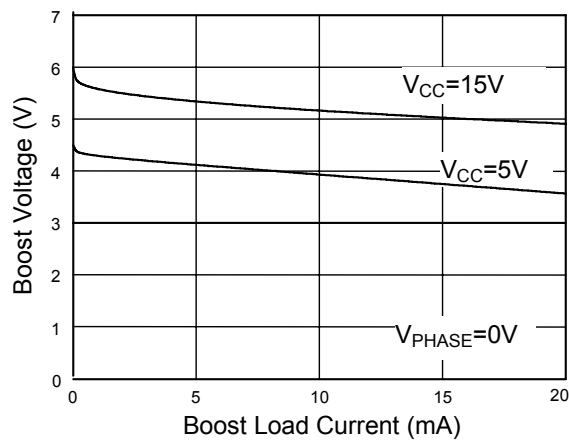


Fig. 6 Boost Load Regulation

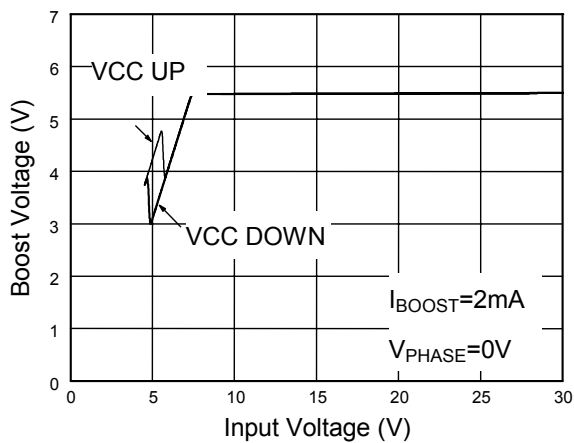


Fig. 7 Boost Line Regulation

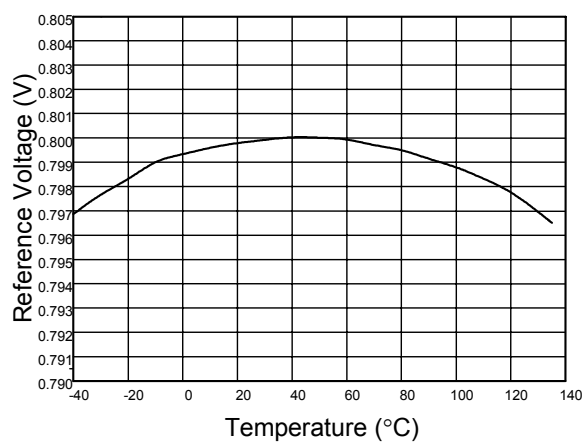


Fig. 8 Reference Voltage vs Temperature

TYPICAL PERFORMANCE CHARACTERISTICS (Continued)

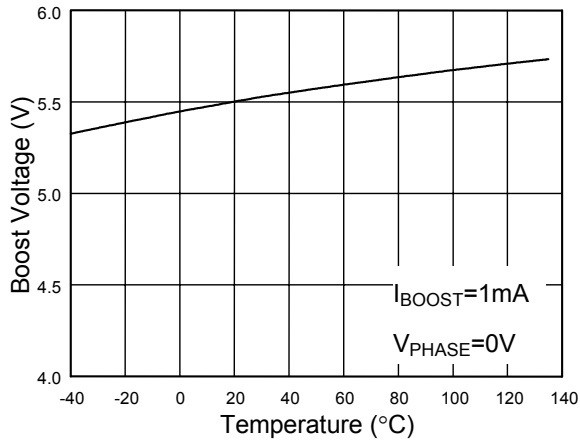


Fig. 9 Boost Voltage vs Temperature

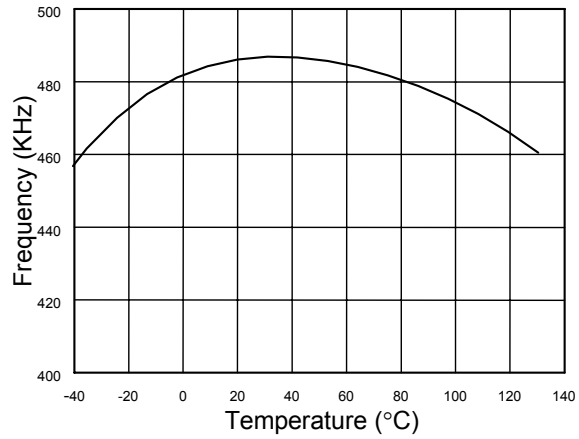


Fig. 10 Operating Frequency vs Temperature

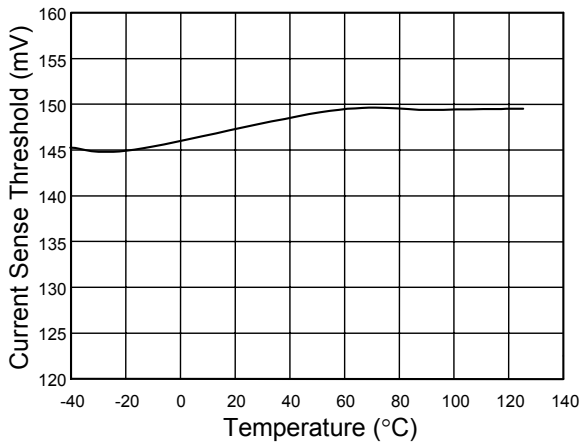
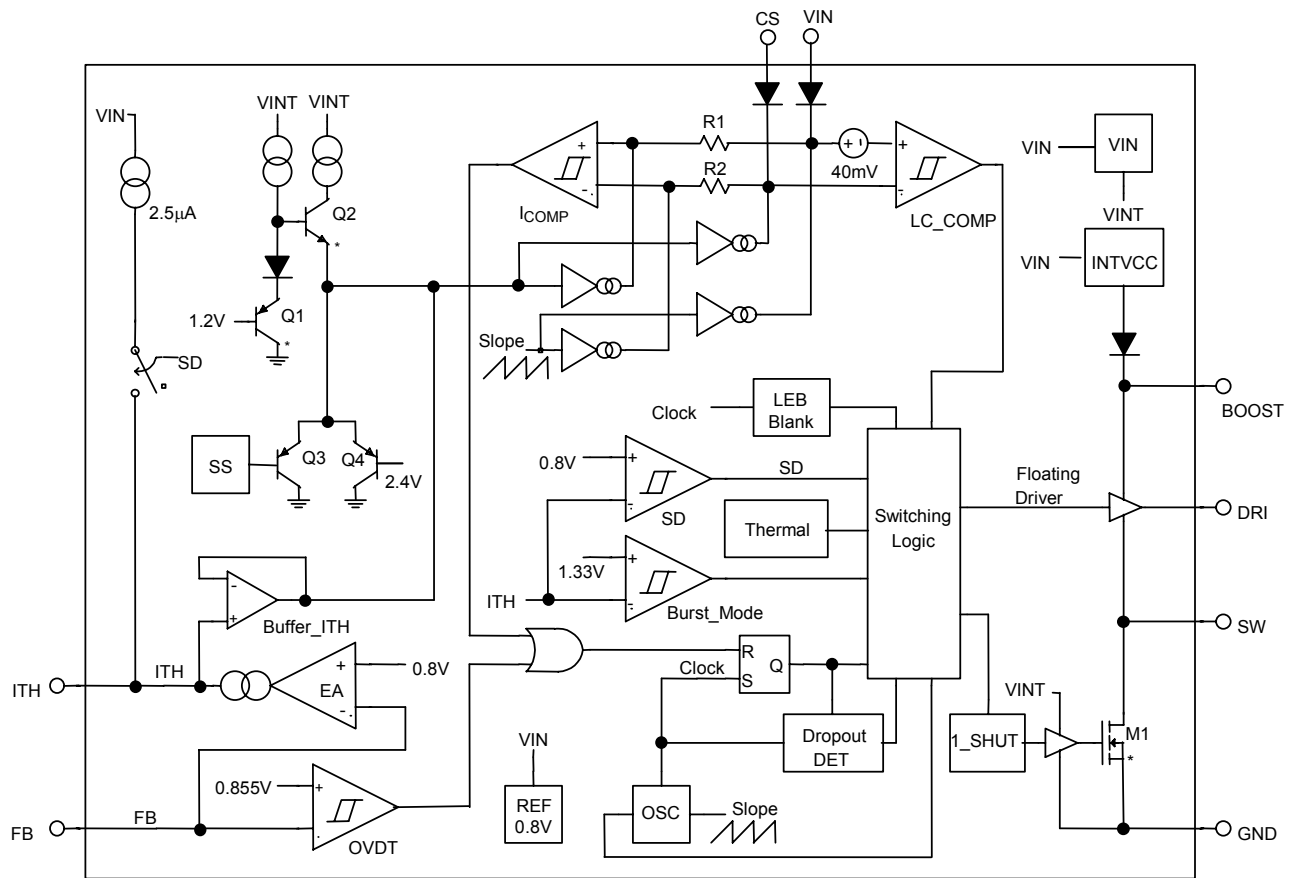


Fig. 11 Maximum Current Sense Threshold vs Temperature

BLOCK DIAGRAM


PIN DESCRIPTIONS

PIN 1: CS - Current sense comparator inverting input, not to exceed V_{IN} voltage. Built in offsets between the CS and V_{IN} pins in conjunction with R_{SENSE} set the current trip thresholds.

PIN 2: I_{TH}/RUN -Combination of error amplifier compensation point and run control inputs. The current comparator threshold increases with this control voltage. Forcing this pin below 0.8V causes the device to be shutdown.

PIN 3: FB - Feedback error amplifier input, to compare the feedback voltage with the internal reference voltage. Connecting a resistor R2 to converter output node and a resistor R1 to ground yields the output voltage:

$$V_{OUT}=0.8 \times (R1+R2)/ R1$$

PIN4: GND - Singal GND for IC. All voltage levels are measured with respect to this pin.

PIN 5: SW - Switch node connection to inductor. In buck converter applications the voltage swing at this pin is from a schottky diode voltage drop below ground to V_{IN}

PIN 6: DRI - External high-side N-MOSFET gate drive pin. Connect DRI to gate of the external high-side N-MOSFET.

PIN 7: BOOST- Supply to high-side floating driver. The bootstrap capacitor C3 is returned to this pin.

PIN 8: VIN - The chip power supply pin. It also provides the gate bias charge for all the MOSFETs controlled by the IC. Recommend supply voltage is 4.5V~24V.

APPLICATION INFORMATION

Introduction

The SS6577 is a current mode switching regulator controller that drives an external N-channel power MOSFET with constant frequency architecture. It uses an external divider to adjust output voltage with excellent line regulation and load regulation. A maximum high duty cycle limit of 95% provides low dropout operation, which extends operating time in battery-operated system.

Wide input voltage ranges from 4.5V to 24V, and a switching frequency of 500KHz allows smaller sized filter components. The operating current level is user-programmable via an external current sense resistor and it automatically enters PFM operation at low output current to boost circuit efficiency.

A multifunction pin (I_{TH}/RUN) allows external compensation plus shutdown. A built-in soft start can properly provide sequenced supplies. Available packages are SOP8 and MSOP8 for SMD.

Principle of Operation

The SS6577 uses a current mode with a constant frequency architecture. Normally high-side MOSFET turns on each cycle when oscillator sets RS latch and it turns off when internal current comparator resets RS latch. Voltage on I_{TH}/RUN pin, which is the output voltage of voltage error amplifier, will control peak inductor current. The output voltage feeds back to V_{FB} pin so that the error amplifier receives a voltage through external resistor divider. When load current increases, it causes a slight decrease

in the voltage of V_{FB} pin. Thus the I_{TH}/RUN voltage remains increasing until the average inductor current matches new load current. While the high-side MOSFET turns off, the low-side MOSFET is turned on to recharge bootstrap capacitor C3.

Main control loop is shutdown when I_{TH}/RUN goes below 0.8V. When I_{TH}/RUN pulled up to 0.8V or up by error amplifier, main control loop is enabled.

Low Current Operation

During heavy load current operation, the SS6577 operates in PWM mode with a frequency of 500KHz. Decreasing of the current will cause a drop in I_{TH}/RUN below 1.33V so that the SS6577 enters PFM mode operation for better efficiency. If the voltage across R_S does not exceed the offset of current comparator within a cycle, then the high-side and internal MOSFETs will disable until I_{TH}/RUN goes over 1.33V.

Component Selection

The SS6577 can be used in many switching regulator applications, such as step-down, step-up, SEPIC and positive-to-negative converters. Among these step-down converter is the most common application. External component selection, beginning with selecting R_S , depends on load requirement of the application. Once R_S is decided, the choice of inductor, which is followed by selecting power MOSFET and diode, can be easily chosen. Finally, C_{IN} and C_{OUT} can be determined.

R_S Selection

The choice of R_S has substantial connection with required output current. The threshold voltage of current comparator decides peak inductor current, which yields a maximum average output current (I_{MAX}), and the peak current is less than half of the peak-to-peak ripple current, ΔI_L .

Allowing a margin for variation of the SS6577, external components can be calculated as:

$$R_S = \frac{100mV}{I_{MAX}}$$

Inductor Selection

With the high operating frequency of 500KHz, smaller inductor values are possible. In general, operating at high frequency will cause low efficiency because of large MOSFET switching loss. Thus the effect of inductor value on ripple current and low current operation must be considered as well.

The inductor value has a direct influence on ripple current (ΔI_L), which decreases with high inductance and increases with high V_{IN} or V_{OUT} :

$$\Delta I_L = \frac{V_{IN} - V_{OUT}}{f \times L} \left(\frac{V_{OUT} + V_D}{V_{IN} + V_D} \right)$$

V_D is the drop voltage of the output Schottky diode.

Accepting a large value of ΔI_L allows the use of low inductance, but yields high output ripple voltage and large core loss. The inductor value also has an effect on low current operation. Low inductor value causes the PFM operation to begin at high load current. The efficiency of the circuit decreases at the beginning of low current operation. Generally speaking, low inductance in PFM mode will cause the efficiency to decrease.

Power MOSFET Selection

For an application of SS6577, an external N-channel power MOSFET, used as the high-side switch, must be properly selected. To prevent MOSFET damage during high input voltage operation, attention should be given to the BV_{DSS} specification of the MOSFET.

Other important selection criteria for the power MOSFET include the "ON" resistance $R_{DS(ON)}$, input voltage and maximum output current.

Output Diode Selection

In order not to exceed the diode ratings, it is important to specify the diode peak current and average power dissipation.

C_{IN} and C_{OUT} Selection

To prevent the high voltage spike resulted from high frequency switching, a low ESR input capacitor for the maximum RMS current must be used. Usually capacitors may be paralleled to meet size or height requirements in the design.

The selection of C_{OUT} depends on the required effective series resistance (ESR). In general once the ESR requirement is met, the capacitance is suitable for filtering. The output ripple voltage (ΔV_{OUT}) is determined by:

$$\Delta V_{OUT} \approx \Delta I_L \left(ESR + \frac{1}{4fC_{OUT}} \right)$$

where f = operating frequency, C_{OUT} = output capacitance and ΔI_L = ripple current of the inductor. Once the ESR requirement for C_{OUT} has been met, the RMS current rating generally far exceeds the I_{RIPPLE(P-P)} requirement.

Topside MOSFET Driver Supply (C3)

External bootstrap capacitor C3 connecting to BOOST pin supplies the gate drive voltage for high-side MOSFET. C3 is charged from INTV_{CC} when SW pin is low. When the high-side MOSFET turns on, the driver places the C3 voltage across the gate to the source of MOSFET. It will enhance the MOSFET and turn on the high-side switch. Then the switch node voltage SW rises to V_{IN} and BOOST pin rises to V_{IN} + INTV_{CC}. In general, 0.1 μ F is acceptable.

Output Voltage Programming

The typical SS6577 application circuit is shown in figure17. A resistive divider, as in the following formula, sets the output voltage.

$$V_{OUT} = 0.8V \left(1 + \frac{R2}{R1} \right)$$

The feedback reference voltage 0.8V allows low output voltages from 0.8V to input voltage. A small capacitor at 1nF in parallel to the upper feedback resistor is required for a stable feedback.

I_{TH}/RUN Function

The I_{TH}/RUN pin, also as a dual-purpose pin, provides loop compensation as well as shutdown function. An internal current source at 2.5 μ A charges up the external capacitor C5. When the voltage on I_{TH}/RUN pin reaches 0.8V, the SS6577 begins to operate.

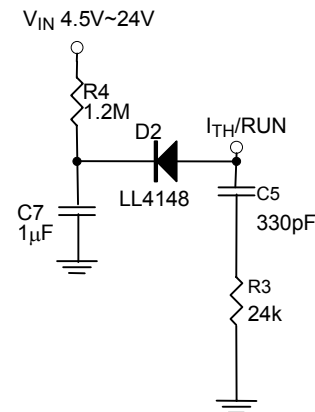


Fig. 12 I_{TH}/RUN pin interfacing

Over Current Protection

Over current protection occurs when the peak inductor current reaches maximum current sense threshold divided by sense resistor. The maximum current under over current protection can be calculated by the following formula.

$$I_{MAX} = \frac{150mV(\text{Maximum current sense threshold})}{R_S}$$

At the same time, the frequency of oscillator will be reduced to sixteenth of original value, 500kHz. This lower frequency allows the inductor current to safely discharge, thereby preventing current runaway. The frequency of oscillator will automatically

return to its designed value when the peak inductor value no longer exceeds over current protection point.

Over Voltage Protection

Over voltage protection occurs when the FB pin voltage (the negative input of error amplifier) exceeds 0.855V. The over voltage comparator will force driver to pull low until output over voltage is removed.

PCB Layout

Since operating at a high switching frequency, 500KHz, proper PCB layout and component placement may enhance the performance of the SS6577 application circuit. For a better efficiency, major loop from input terminal to output terminal should be as

short as possible. In addition, in the case of a large current loop, the track width of each component in the loop should maintain as wide as possible.

In order to prevent the effect from noise, the GND pin should be placed close to the ground. Also keep the IC's GND pin and the ground leads in the shortest distance. Recommended layout diagrams and component placement are as shown as figures 13 to 16. No sensitive components, which may cause noise interference to the circuit, should be allowed to be close to SW pin.

Furthermore, the SS6577 is a current-mode controller. Keeping the sense resistor close to both VIN and CS pins is recommended for better efficiency and output performance. In addition, all filtering and decoupling capacitors, such as C1 and C2, should connect to the SS6577 as close as possible.

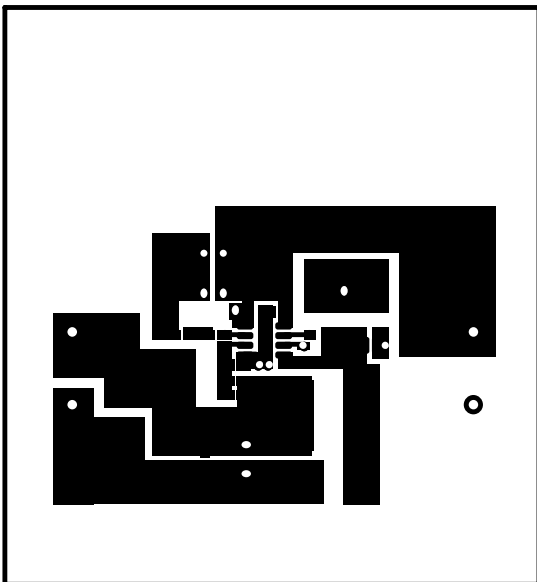


Fig. 12 Top Layer

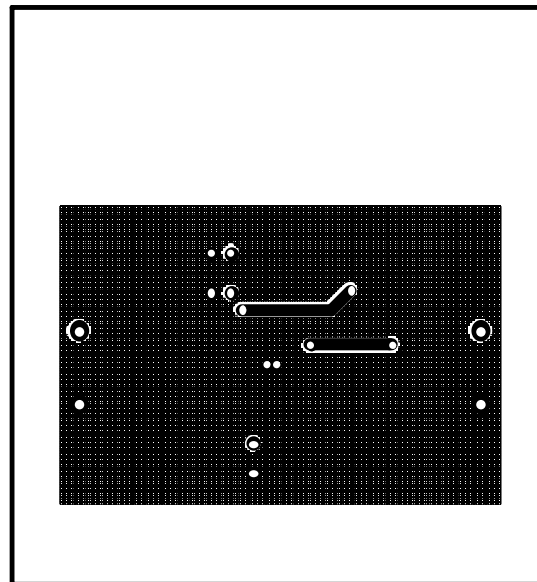


Fig. 13 Bottom Layer

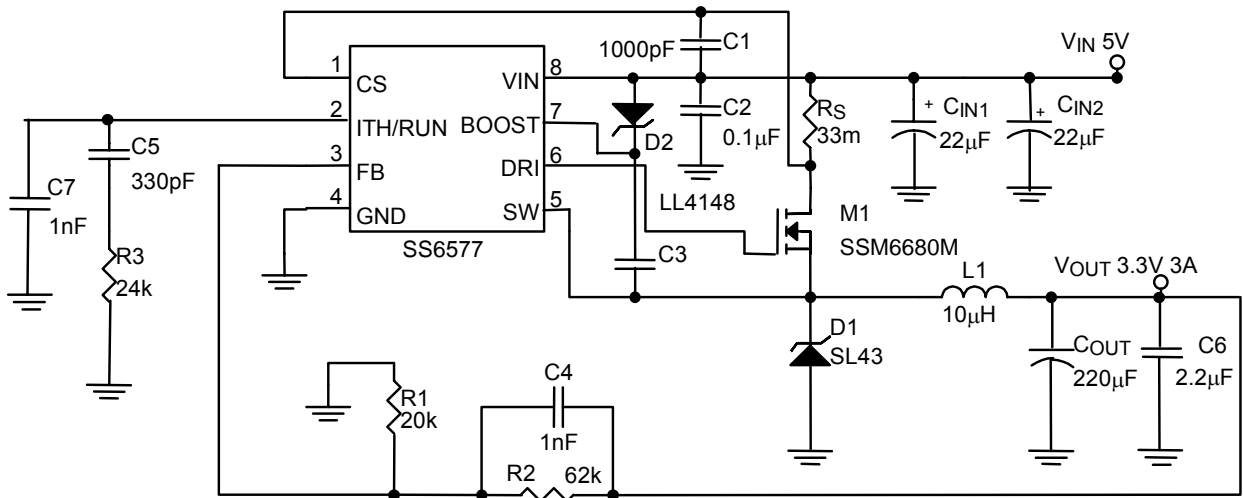
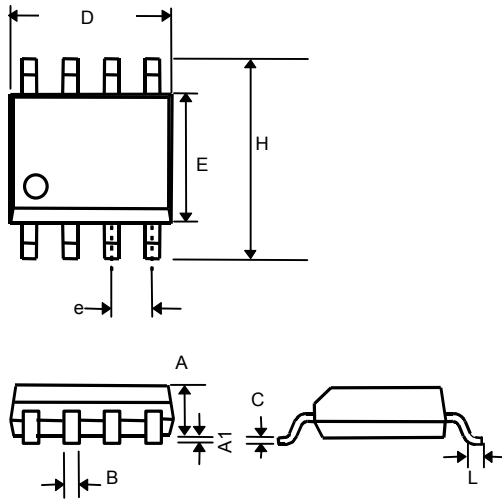
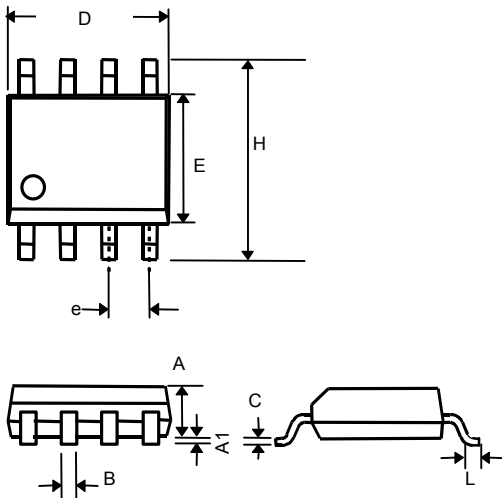


Fig. 17 5V to 3.3V Step-Down Converter

PHYSICAL DIMENSIONS (unit: mm)
8 LEAD PLASTIC SO (CS)


SYMBOL	MIN	MAX
A	1.35	1.75
A1	0.10	0.25
B	0.33	0.51
C	0.19	0.25
D	4.80	5.00
E	3.80	4.00
e	1.27(TYP)	
H	5.80	6.20
L	0.40	1.27

MSOP 8 (CO)


SYMBOL	MIN	MAX
A	0.76	0.97
A1	--	0.20
B	0.28	0.38
C	0.13	0.23
D	2.90	3.10
E	2.90	3.10
e	0.65	
H	4.80	5.00
L	0.40	0.66

Information furnished by Silicon Standard Corporation is believed to be accurate and reliable. However, Silicon Standard Corporation makes no guarantee or warranty, express or implied, as to the reliability, accuracy, timeliness or completeness of such information and assumes no responsibility for its use, or for infringement of any patent or other intellectual property rights of third parties that may result from its use. Silicon Standard reserves the right to make changes as it deems necessary to any products described herein for any reason, including without limitation enhancement in reliability, functionality or design. No license is granted, whether expressly or by implication, in relation to the use of any products described herein or to the use of any information provided herein, under any patent or other intellectual property rights of Silicon Standard Corporation or any third parties.