

1.4MHz Current-Mode Step-Up DC/DC Converter

Features

- Fixed-frequency 1.4MHz Current-Mode PWM operation.
- Adjustable output voltage up to 30V.
- Guaranteed 13V/ 200mA output with 5V Input.
- Input Range 2.5V to 10V.
- Maximum 0.1 μ A shutdown current.
- Programmable soft-start.
- Works with tiny inductors and capacitors
- Space-saving SOT-23-6 package.

Applications

- White LED Backlight.
- OLED Driver.

Typical Application Circuits

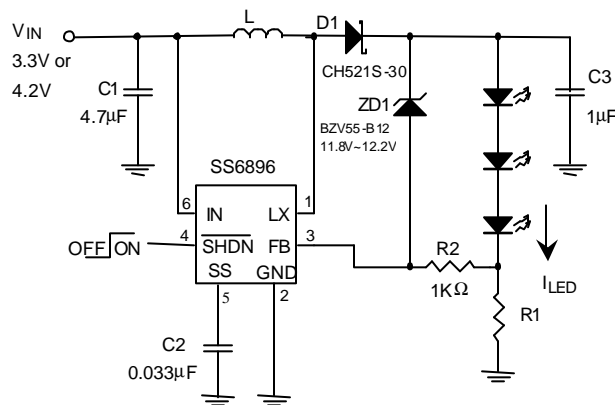

Fig. 1 Li-Ion Powered Driver for three white LEDs

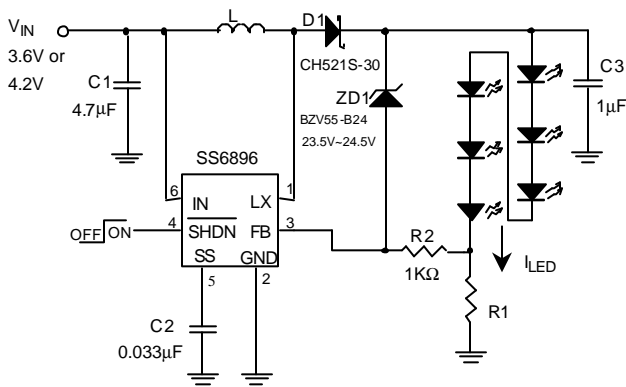
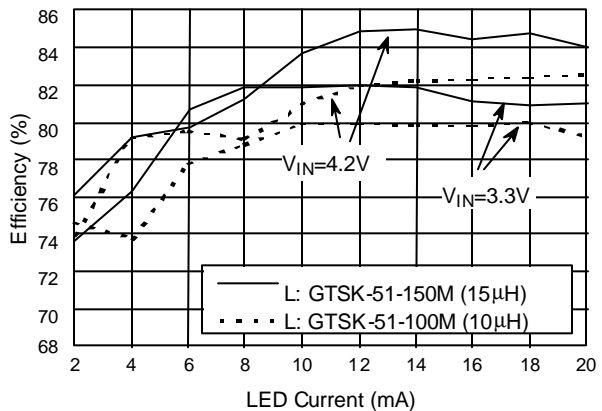
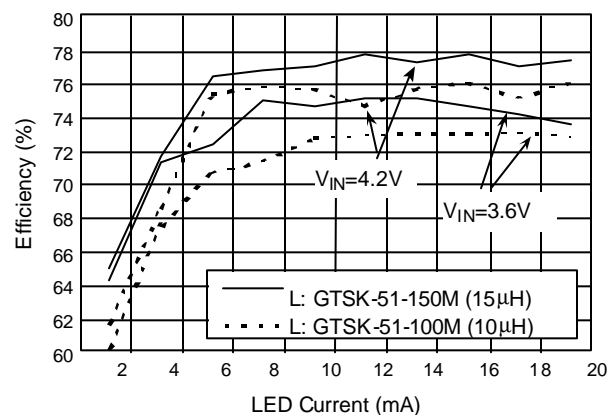
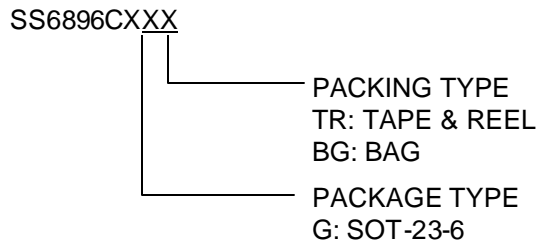

Fig. 2 Li-Ion Powered Driver for six white LEDs



Ordering Information



Pin Configuration

SOT-23-6 (CG)
FRONT VIEW

1: LX
2: GND
3: FB
4: SHDN
5: SS
6: IN

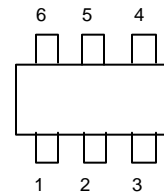

Example: SS6896CGTR
→ in SOT-23-6 package in tape and reel.

● SOT-23-6 Marking

Part No.	Marking
SS6896CG	1896

Absolute Maximum Ratings

LX to GND	-0.3V to +33V
FB to GND	-0.3V to +6V
IN, $\overline{\text{SHDN}}$	-0.3V to +11V
SS to GND	-0.3V to +6V
LX Pin RMS Current	0.6A
Continuous Power Dissipation ($T_A = +70^\circ\text{C}$) (Note 1)	
6-Pin SOT23 (derate 9.1mW/ $^\circ\text{C}$ above +70 $^\circ\text{C}$).....	727mW
Operating Temperature Range	-40 $^\circ\text{C}$ to +85 $^\circ\text{C}$
Junction Temperature	+150 $^\circ\text{C}$
Storage Temperature Range	-65 $^\circ\text{C}$ to +150 $^\circ\text{C}$
Lead Temperature (soldering, 10s).....	+300 $^\circ\text{C}$

Note 1: Thermal properties are specified with product mounted on PC board with one square-inch of copper area and still air.

Test Circuit

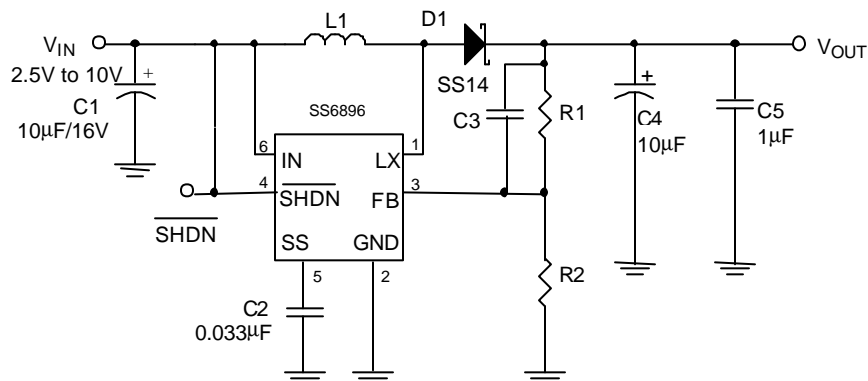

Electrical Characteristics ($V_{IN}=V_{\overline{SHDN}}=3V$, $FB=GND$, $SS=Open$, $T_A = -40^{\circ}C$ to $85^{\circ}C$, unless otherwise specified)

PARAMETER	SYMBOL	CONDITIONS	MIN	TYP	MAX	UNITS
Input Supply Range	V_{IN}		2.5		10	V
Output Voltage Adjust Range	V_{OUT}				30	V
V_{IN} Undervoltage Lockout	UVLO	V_{IN} rising, 50mV hysteresis		2.2		V
Quiescent Current	I_{IN}	$V_{FB} = 1.3V$, not switching		0.1	0.2	mA
		$V_{FB} = 1.0V$, switching		1	5	
Shutdown Supply Current		$V_{\overline{SHDN}} = 0$, $T_A = +25^{\circ}C$		0.01	0.5	μA
		$V_{\overline{SHDN}} = 0$		0.01	10	μA
ERROR AMPLIFIER						
Feedback Regulation Set Point	V_{FB}		1.205	1.23	1.255	V
FB Input Bias Current	I_{FB}	$V_{FB} = 1.24V$		21	80	nA
Line Regulation		$2.6V < V_{IN} < 5.5V$		0.05	0.20	%/V
OSCILLATOR						
Frequency	f_{OSC}		1000	1400	1800	KHz
Maximum Duty Cycle	DC		82	86		%
POWER SWITCH						
Steady State Output Current	I_o	Refer to Fig. 18				A
On-Resistance	$R_{DS(ON)}$			1	1.4	Ω
Leakage Current	$I_{LX(OFF)}$	$V_{LX} = 12V$, $T_A = +25^{\circ}C$		0.1	1	μA
		$V_{LX} = 12V$			10	
SOFT-START						
Reset Switch Resistance					100	Ω
Charge Current		$V_{SS} = 1.2V$	1.5	4	7.0	μA
CONTROL INPUT						
Input Low Voltage	V_{IL}	$V_{\overline{SHDN}}$, $V_{IN} = 2.5V$ to $10V$			0.3	V
Input High Voltage	V_{IH}	$V_{\overline{SHDN}}$, $V_{IN} = 2.5V$ to $10V$	1.0			V
\overline{SHDN} Input Current	$I_{\overline{SHDN}}$	$V_{\overline{SHDN}} = 3V$		25	50	μA
		$V_{\overline{SHDN}} = 0$		0.01	0.1	

Typical Performance Characteristics

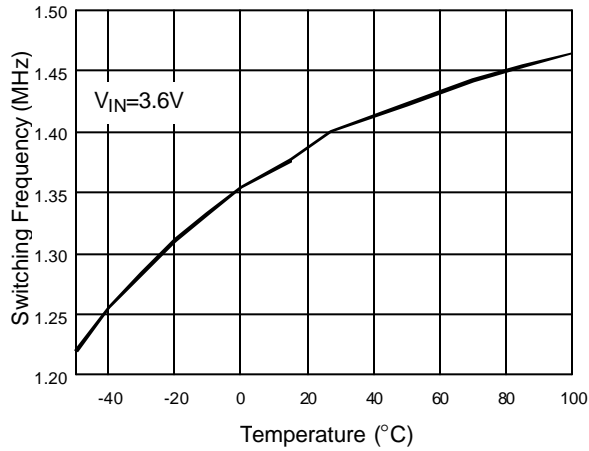

Fig. 3 Switching Frequency vs. Temperature

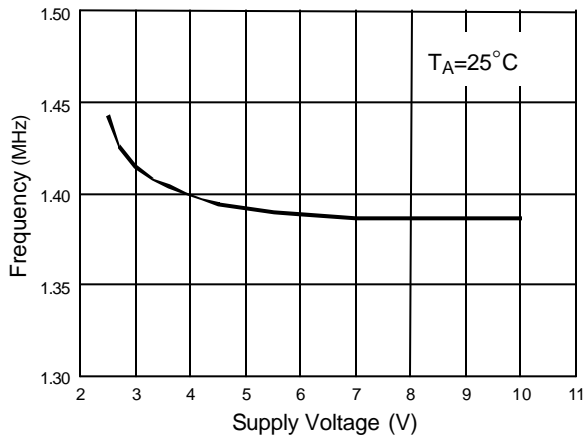

Fig. 4 Frequency vs. Supply Voltage

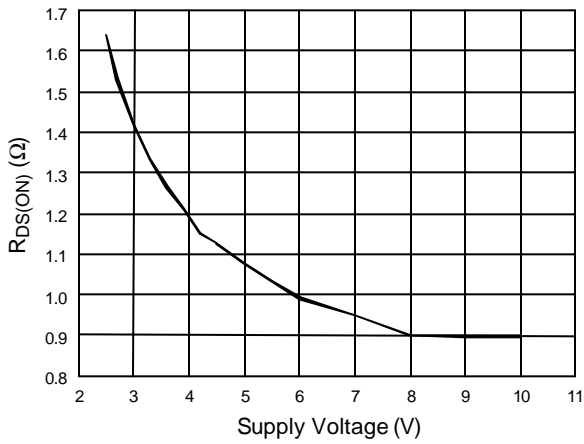

Fig. 5 R_{DS(ON)} vs. Supply Voltage

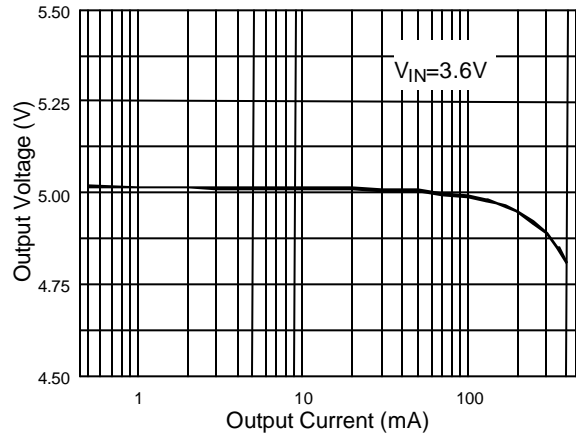

Fig. 6 Load Regulation (L1=10uH)

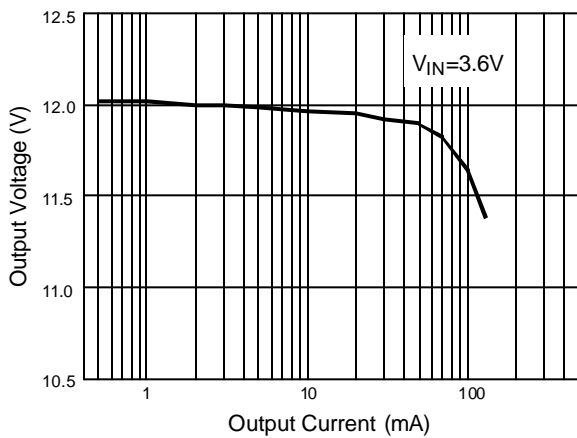

Fig. 7 Load Regulation (L1=22uH)

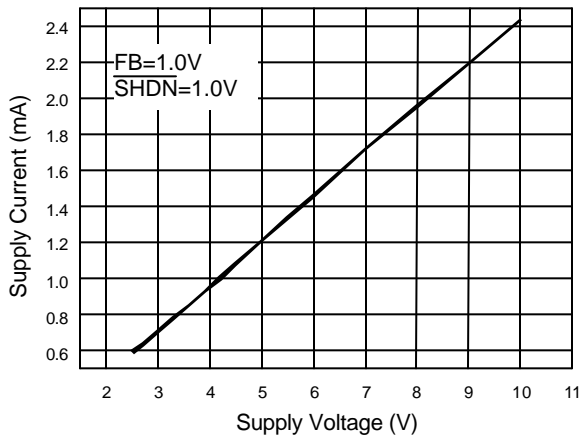

Fig. 8 Switching Current

Typical Performance Characteristics (Continued)

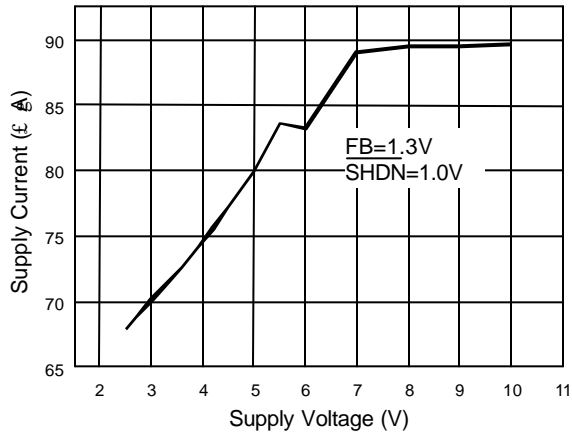

Fig. 9 Non-Switching Current

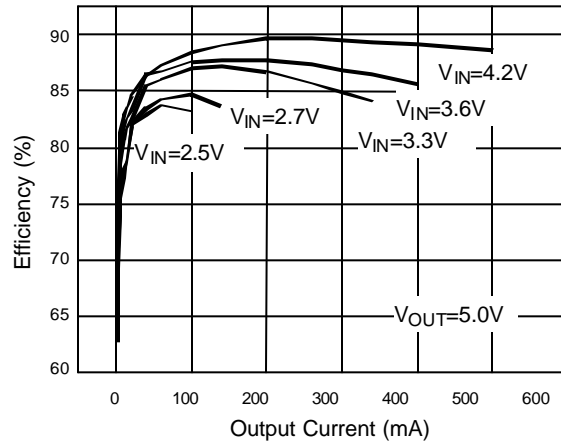

Fig. 10 Efficiency vs. Output Current (L1=10μH)

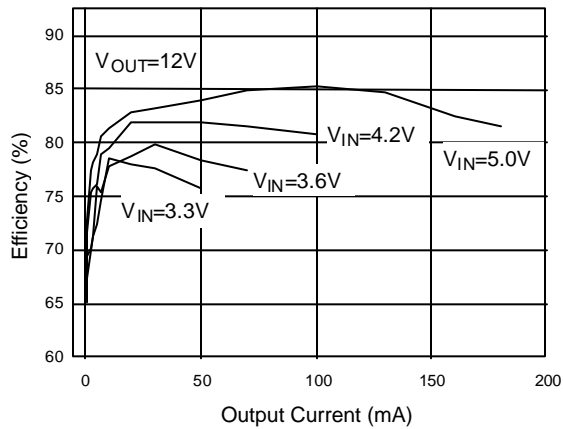

Fig. 11 Efficiency vs. output current (L1=22μH)

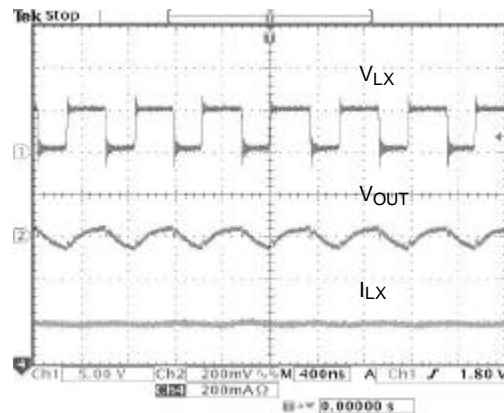

Fig. 12 Operation Wave Form

($V_{IN}=3V$; $V_{OUT}=5V$; $L1=10\mu H$; $R1=36K$; $R2=12K$; $C3=39pF$; $I_{OUT}=200mA$)

Typical Performance Characteristics (Continued)

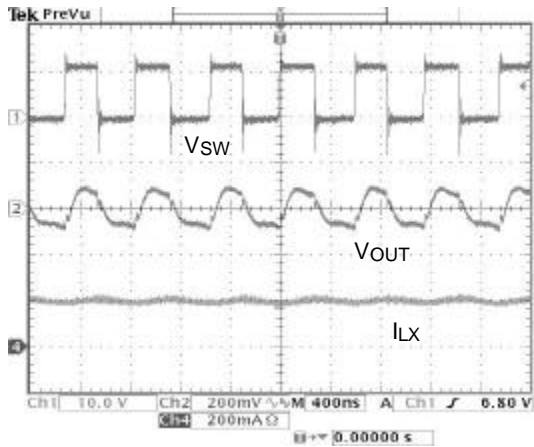

Fig. 13 Operation Wave Form
 $(V_{IN}=5V; V_{OUT}=12V; L1=22\mu H; R1=105K;$
 $R2=12K; C3=1nF; I_{OUT}=200mA)$

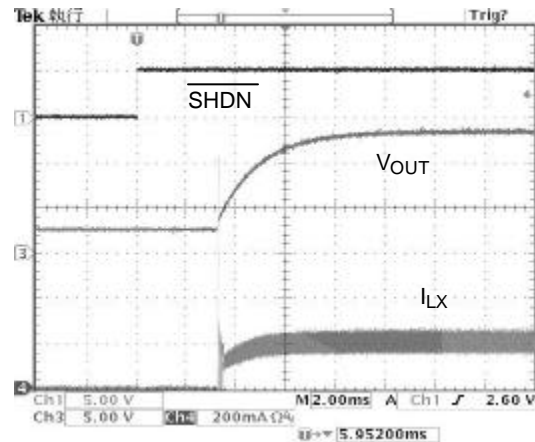

Fig. 14 Start-Up from Shutdown
 $(V_{IN}=3.3V; V_{OUT}=13V; R_{LOAD}=300\Omega)$

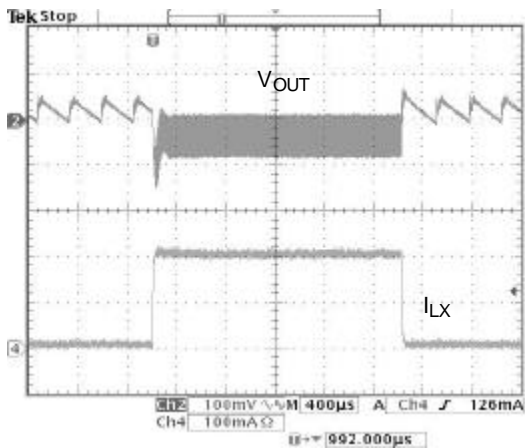

Fig. 15 Load Step Response
 $(V_{IN}=3.3V; V_{OUT}=5V; L1=10\mu H; I_{OUT}=5mA \text{ to } 200mA)$

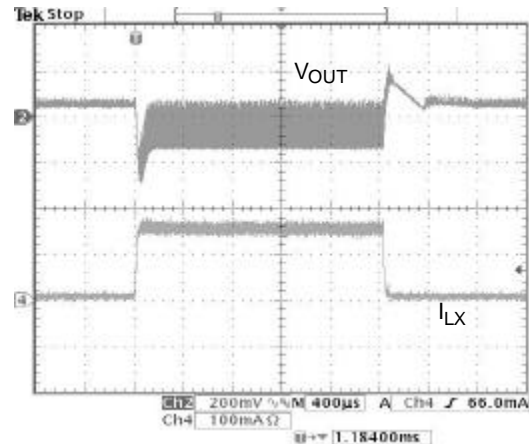

Fig. 16 Load Step Response
 $(V_{IN}=5V; V_{OUT}=12V; L1=22\mu H; I_{OUT}=5mA \text{ to } 150mA)$

Typical Performance Characteristics (Continued)

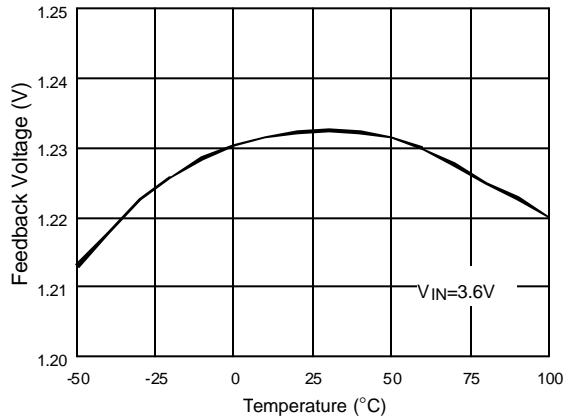

Fig. 17 Feedback Pin Voltage

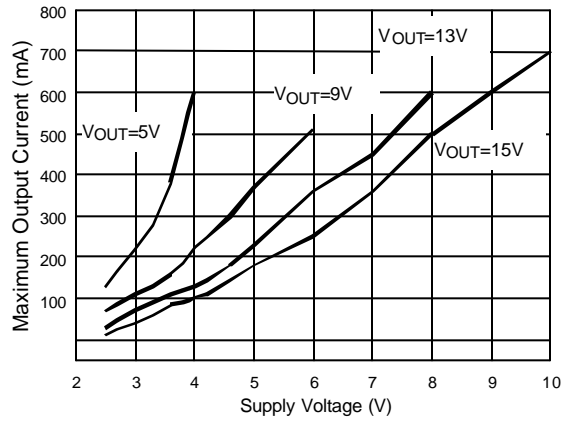
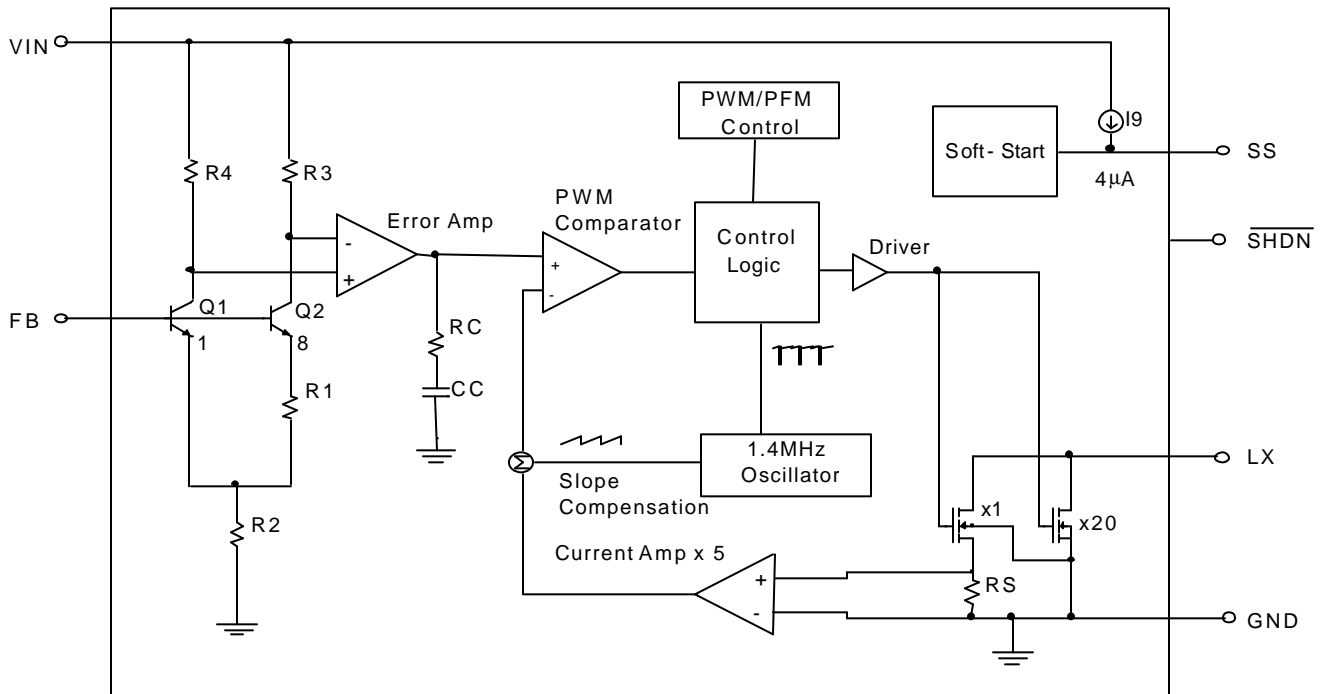

Fig. 18 Maximum Output current vs. Supply Voltage (L1:10μH V_o=5V,9V ; L1=22μH V_o=13V,15V)

Block Diagram



Pin Descriptions

- PIN 1: LX - Power Switching Connection. Connect LX to inductor and output rectifier. Keep the distance between the components as close to LX as possible.
- PIN 2: GND - Ground.
- PIN 3: FB - Feedback Input. Connect a resistive voltage-divider from the output to FB to set the output voltage.
- PIN 4: $\overline{\text{SHDN}}$ - Shutdown Input. Drive $\overline{\text{SHDN}}$ low to turn off the converter. To automatically start the converter, connect $\overline{\text{SHDN}}$ to IN. Drive $\overline{\text{SHDN}}$ with a slew rate of $0.1\text{V}/\mu\text{s}$ or greater. Do not leave $\overline{\text{SHDN}}$ unconnected. $\overline{\text{SHDN}}$ draws up to $50\mu\text{A}$.
- PIN 5: SS - Soft-Start Input. Connect a soft-start capacitor from SS to GND in order to soft-start the converter. Leave SS open to disable the soft-start function.
- PIN 6: IN - Internal Bias Voltage Input. Connect IN to the input voltage source. Bypass IN to GND with a capacitor sitting as close to IN as possible.

Application Information

Inductor Selection

A 15 μ H inductor is recommended for most SS6896 applications. Although small size and high efficiency are major concerns, the inductor should have low core losses at 1.4MHz and low DCR (copper wire resistance).

Capacitor Selection

The small size of ceramic capacitors makes them ideal for SS6896 applications. X5R and X7R types are recommended because they retain their capacitance over wider ranges of voltage and temperature than other types, such as Y5V or Z5U. A 4.7 μ F input capacitor and a 1 μ F output capacitor are sufficient for most SS6896 applications.

Diode Selection

Schottky diodes, with their low forward voltage drop and fast reverse recovery, are the ideal choices for SS6896 applications. The forward voltage drop of a Schottky diode represents the conduction losses in the diode, while the diode capacitance (CT or CD) represents the switching losses. For diode selection, both forward voltage drop and diode capacitance need to be considered. Schottky diodes with higher current ratings usually have lower forward voltage drop and larger diode capacitance, which can cause significant switching losses at the 1.4MHz switching frequency of the SS6896. A Schottky diode rated at 100mA to 200mA is sufficient for most SS6896 applications.

LED Current Control

LED current is controlled by a feedback resistor (R1 in Fig. 1). The feedback reference is 1.23V. The LED current is $1.23V/R1$. In order to have accurate LED current, precision resistors are preferred (1% recommended). The formula for R1 selection is shown below.

$$R1 = 1.23V/I_{LED} \quad (1)$$

Open-Circuit Protection

In the cases of output open-circuit, when the LEDs are disconnected from the circuit or the LEDs fail, the feedback voltage will be zero. The SS6896 will then switch to a high duty cycle resulting in a high output voltage, which may cause the SW pin voltage to exceed its maximum 30V rating. A zener diode can be used at the output to limit the voltage on the SW pin (Fig. 20). The zener voltage should be larger than the maximum forward voltage of the LED string. The current rating of the zener should be larger than 0.1mA.

Dimming Control

There are three different types of dimming control circuits as follows:

1. Using a PWM signal

PWM brightness control provides the widest dimming range by pulsing the LEDs on and off using the control signal. The LEDs operate at either zero or full current. The average LED current changes with the duty cycle of the PWM signal. Typically, a 1kHz to 10kHz PWM signal is used. PWM dimming with the SS6896 can be accomplished two different ways (see Fig. 21). The $\overline{\text{SHDN}}$ pin can be driven directly or a resistor can be added to drive the FB pin. If the $\overline{\text{SHDN}}$ pin is used, increasing the duty cycle will increase the LED brightness. If the FB pin is used, increasing the duty cycle will decrease the brightness. Using this method, the LEDs are dimmed using FB and turned off completely using $\overline{\text{SHDN}}$.

2. Using a DC Voltage

For some applications, the preferred method of brightness control uses a variable DC voltage to adjust the LED current. The dimming control using a

DC voltage is shown in Fig. 22. As the DC voltage increases, the voltage drop on R2 increases and the voltage drop on R1 decreases.

Thus, the LED current decreases. The selection of R2 and R3 should make the current from the variable DC source much smaller than the LED current and much larger than the FB pin bias current. For VDC range from 0V to 5V, the selection of resistors in Fig. 22 gives dimming control of LED current from 20mA to 0mA.

3. Using a Filtered PWM Signal

The filtered PWM signal can be considered as an adjustable DC voltage. It can be used to replace the variable DC voltage source in dimming control. The circuit is shown in Fig. 23.

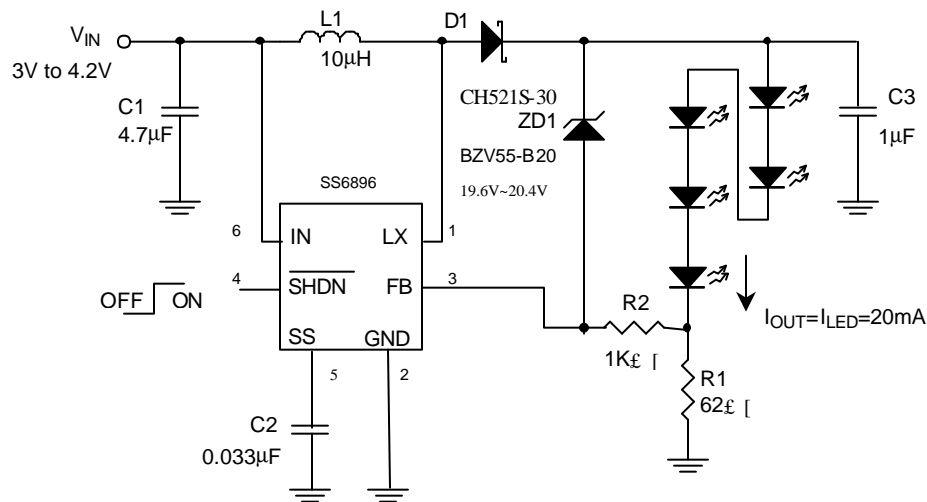

Fig. 20 White LED driver with open-circuit protection

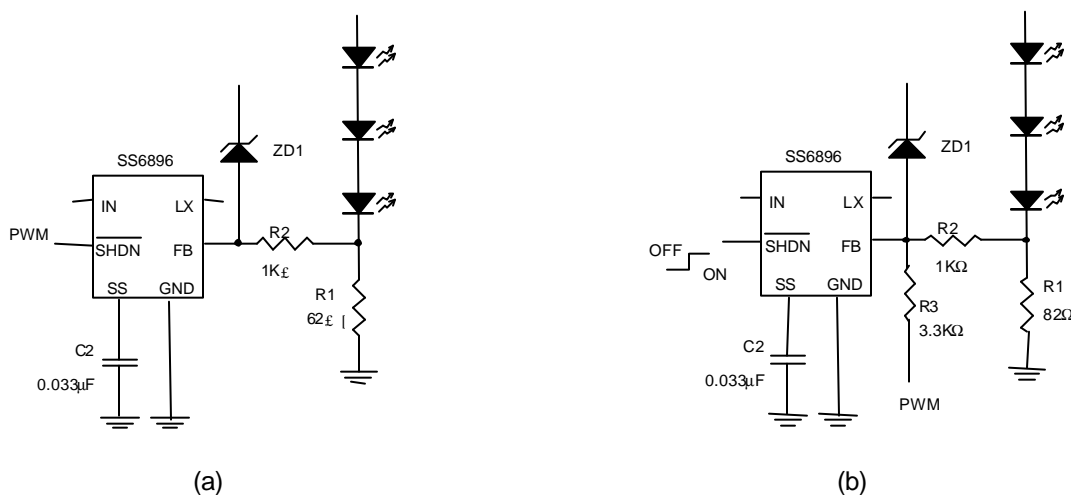

Fig. 21 Dimming-control using a PWM signal

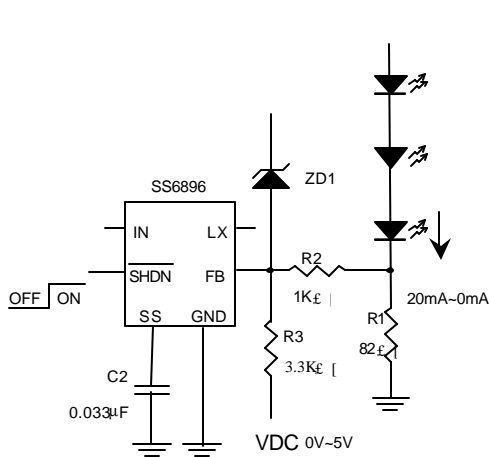

Fig. 22 Dimming-control using a DC voltage

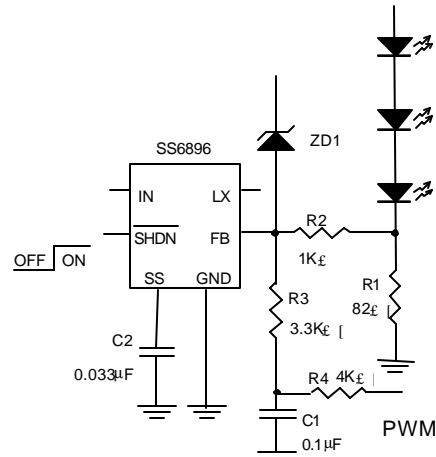

Fig. 23 Dimming-control using a filtered PWM signal

Application Example

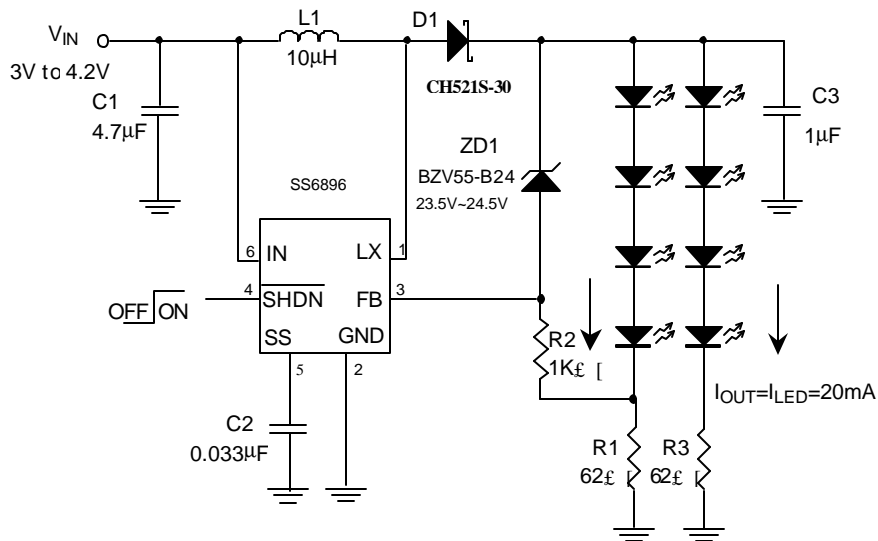
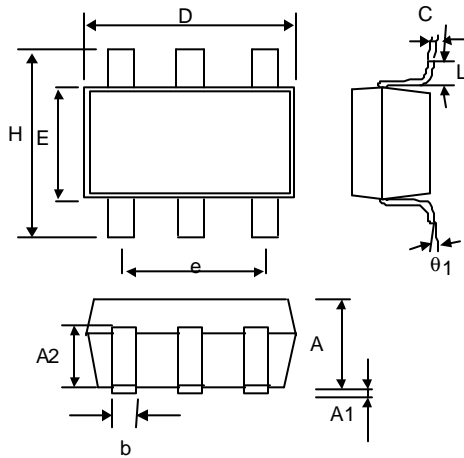

Fig. 24 Li-Ion powered driver for eight white LEDs with open-circuit protection

Physical Dimensions

- SOT-23-6 (unit: mm)



SYMBOL	MIN	MAX
A	1.00	1.30
A1	—	0.10
A2	0.70	0.90
b	0.35	0.50
C	0.10	0.25
D	2.70	3.10
E	1.60	2.00
e	1.90 (TYP)	
H	2.60	3.00
L	0.37	—
θ_1	1°	9°

Information furnished by Silicon Standard Corporation is believed to be accurate and reliable. However, Silicon Standard Corporation makes no guarantee or warranty, express or implied, as to the reliability, accuracy, timeliness or completeness of such information and assumes no responsibility for its use, or for infringement of any patent or other intellectual property rights of third parties that may result from its use. Silicon Standard reserves the right to make changes as it deems necessary to any products described herein for any reason, including without limitation enhancement in reliability, functionality or design. No license is granted, whether expressly or by implication, in relation to the use of any products described herein or to the use of any information provided herein, under any patent or other intellectual property rights of Silicon Standard Corporation or any third parties.