

3.3V 600mA Low Dropout Regulator

FEATURES

- Dropout voltage typically 0.65V @ $I_o = 600\text{mA}$.
- Output current in excess of 600mA.
- Output voltage accuracy +%.
- Quiescent current, typically 0.3mA.
- Internal short circuit current limit.
- Internal over temperature protection.

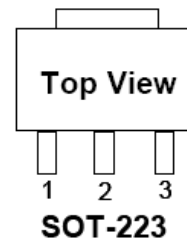

GENERAL DESCRIPTION

The SS8044 positive 3.3V voltage regulator features the ability to source 600mA of output current with a dropout voltage of typically 0.65V. A low quiescent current is provided. The typical quiescent current is 0.3mA.

Familiar regulator features such as over temperature and over current protection circuits are provided to prevent it from being damaged by abnormal operating conditions.



Pb-free; RoHS-compliant

TYPICAL APPLICATIONS

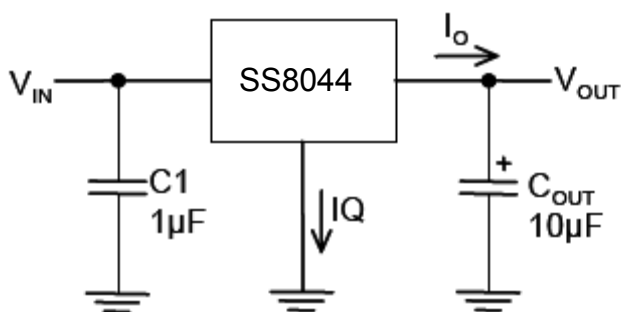

MAXIMUM RATINGS ($T_A=25^{\circ}\text{C}$ unless otherwise specified)

Input Voltage.....	7V
Power Dissipation Internally Limited	(Note2)
Maximum Junction Temperature.....	150°C
Storage Temperature Range.....	-65°C T_J +150°C
Reflow Temperature (soldering, 10sec).....	260°C
Thermal Resistance Junction to Ambient, (θ_{JA})	
SOT-223.....	147°C/W
Thermal Resistance Junction to Case, (θ_{JC})	
SOT-223.....	27°C/W

OPERATING CONDITIONS

Input Voltage.....	4V ~ 6.5V
Temperature Range.....	-40°C T_A 85°C

ELECTRICAL CHARACTERISTICS
 $V_{IN} = 5\text{V}$, $I_O = 600\text{mA}$, $C_{IN}=10\mu\text{F}$, $C_{OUT} = 10\mu\text{F}$. All specifications apply for $T_A = T_J = 25^{\circ}\text{C}$. [Note 3]

PARAMETER	CONDITION	MIN	TYP	MAX	UNIT
Output Voltage	10mA < I_O < 600mA	3.234	3.3	3.366	V
Line Regulation	4V < V_{IN} < 6V, $I_O = 10\text{mA}$	---	15	---	mV
Load Regulation	10mA < I_O < 600mA	---	20	---	mV
	10mA < I_O < 250mA	---	10	---	
Quiescent Current	$V_{IN} = 5\text{V}$	---	0.3	---	mA
Ripple Rejection	$f_i = 120\text{ Hz}$, 1VP-P, $I_O = 100\text{mA}$	---	47	---	dB
Dropout Voltage	$I_O = 600\text{mA}$	---	0.65	---	V
	$I_O = 250\text{mA}$	---	0.25	---	
Output Current		---	600	---	mA
Short Circuit		---	0.65	---	A
Current Limit			0.8		A
Over Temperature		---	145	---	°C

- NOTE:**
1. Absolute Maximum Ratings are limits beyond which damage to the device may occur. Operating Conditions are conditions under which the device functions but the specifications might not be guaranteed. For guaranteed specifications and test conditions see the Electrical Characteristics.
 2. The maximum power dissipation is a function of the maximum junction temperature, T_{Jmax} ; total thermal resistance, J_A , and ambient temperature T_A . The maximum allowable power dissipation at any ambient temperature is $T_{Jmax}-T_A / J_A$. If this dissipation is exceeded, the die temperature will rise above 150°C and IC go into thermal shutdown. The J_A of SOT-223 package is 147°C/W (See Recommended Minimum Footprint).
 3. Low duty pulse techniques are used during test to maintain junction temperature as close to ambient as possible.
 4. The type of output capacitor should be tantalum or aluminum.

DEFINITIONS

Dropout Voltage

The input/output Voltage differential at which the regulator output no longer maintains regulation against further reductions in input voltage. Measured when the output drops 100mV below its nominal value, dropout voltage is affected by junction temperature, load current and minimum input supply requirements.

Line Regulation

The change in output voltage for a change in input voltage. The measurement is made under conditions of low dissipation or by using pulse techniques such that average chip temperature is not significantly affected.

Load Regulation

The change in output voltage for a change in load current at constant chip temperature. The measurement is made under conditions of low dissipation or by using pulse techniques such that average chip temperature is not significantly affected.

Maximum Power Dissipation

The maximum total device dissipation for which the regulator will operate within specifications.

Quiescent Bias Current

Current which is used to operate the regulator chip and is not delivered to the load.

RATINGS AND CHARACTERISTIC CURVES

($V_{IN} = +5V$, $C_{IN} = 10\mu F$, $C_{OUT} = 10\mu F$, $T_A = 25^\circ C$, unless otherwise specified.)

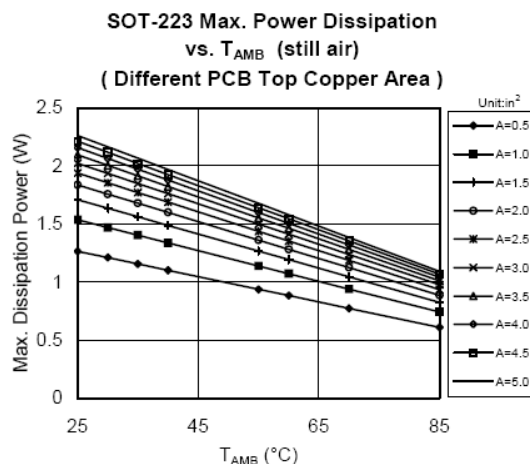
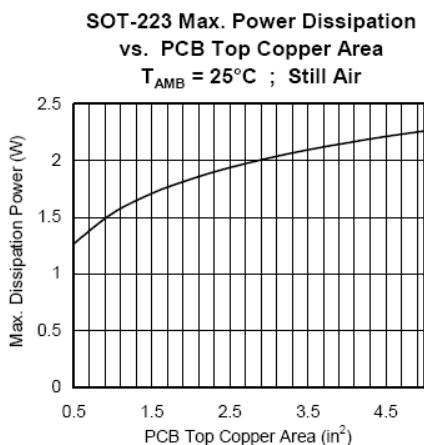

RATINGS AND CHARACTERISTIC CURVES

(VIN = +5V , CIN = 10 μ F, COUT = 10 μ F, TA = 25°C , unless otherwise specified.)

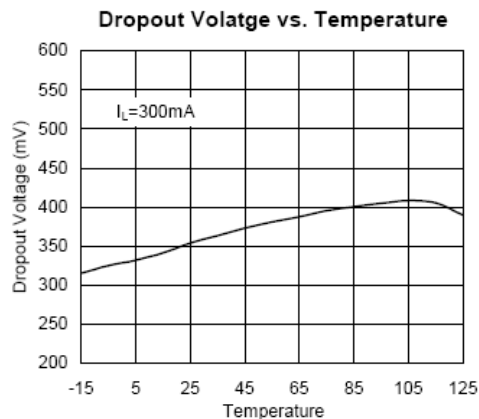
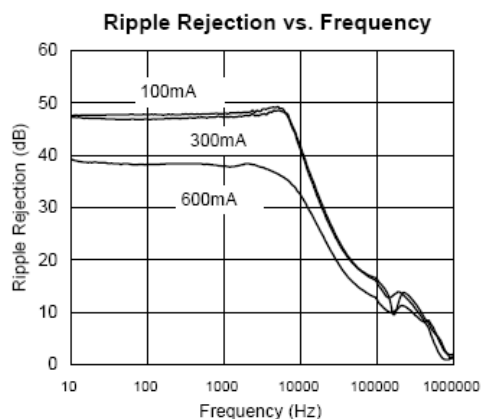
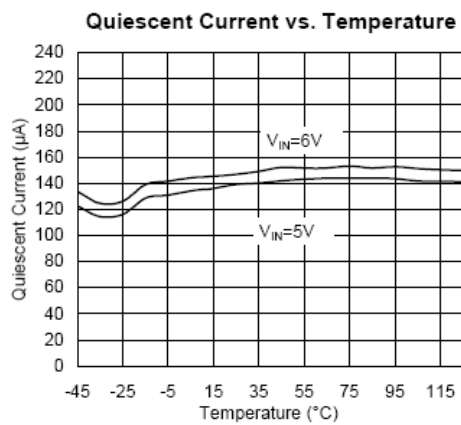
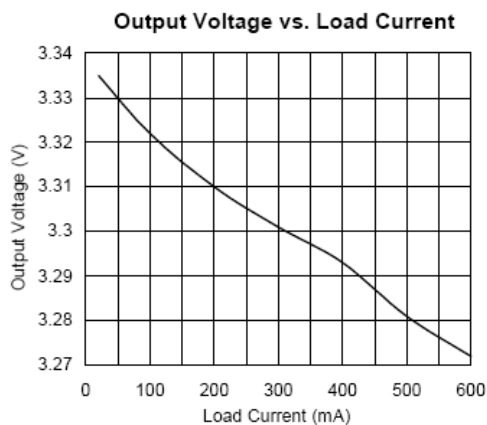
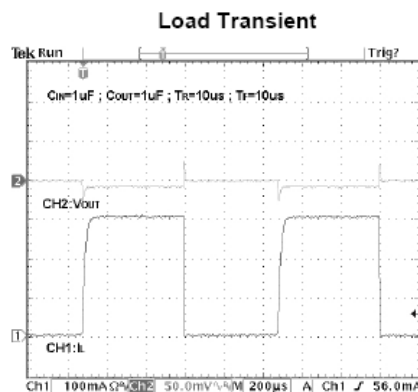
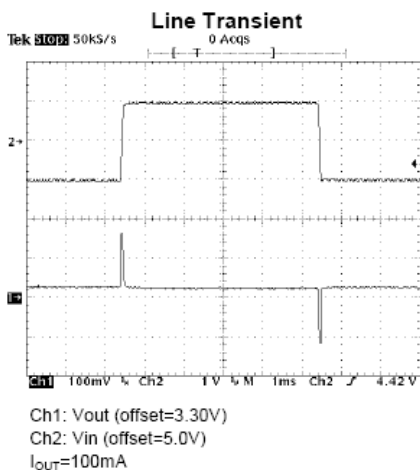

MINIMUM FOOTPRINT

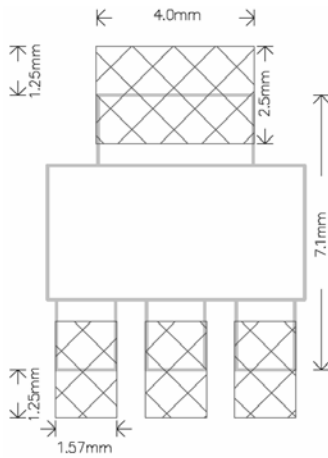

ORDER INFORMATION

SSXXX(G) XX X X

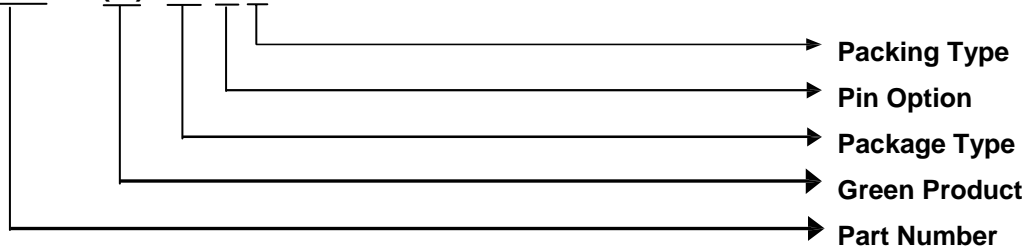

PACKAGE TYPE

T6: SOT223

PIN OPTION

1	2	3
1 : VOUT	GND	VIN
2 : VOUT	VIN	GND
3 : GND	VOUT	VIN
4 : GND	VIN	VOUT
5 : VIN	GND	VOUT
6 : VIN	VOUT	GND

PACKING

U & D : Tape & Reel
T : Tube
B : Bag

Disclaimer

Information furnished by Silicon Standard Corporation is believed to be accurate and reliable. However, Silicon Standard Corporation makes no guarantee or warranty, expressed or implied, as to the reliability, accuracy, timeliness or completeness of such information and assumes no responsibility for its use, or for infringement of any patent or other intellectual property rights of third parties that may result from its use. Silicon Standard reserves the right to make changes as it deems necessary to any products described herein for any reason, including without limitation enhancement in reliability, functionality or design. No license is granted, whether expressly or by implication, in relation to the use of any products described herein or to the use of any information provided herein, under any patent or other intellectual property rights of Silicon Standard Corporation or any third parties.